

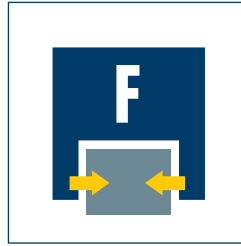

**Sizes**  
50 .. 125



**Weight**  
0.3 kg .. 5.3 kg



**Gripping force**  
240 N .. 1970 N



**Stroke per finger**  
7.5 mm .. 31.5 mm



**Workpiece weight**  
1.2 kg .. 7.1 kg

### Application example



Assembly unit for mounting a pin in a bore with tolerances for the position. The compensation unit compensates for the planar offset without turning the workpiece or allowing it to tilt.

**1** PGF 80 2-Finger Parallel Gripper with special fingers and workpiece (pin)

**2** AGE-XY-80 Compensation Unit

## Universal Gripper

Universal parallel gripper with surface-guided base jaws

### Area of application

Suitable for clean working environments and high part diversity thanks to its long jaw stroke and high gripping forces

### Your advantages and benefits

#### Precise flat guide

for very good guidance characteristics

#### Long stroke despite a compact design

for minimal interfering contours

#### Mounting from two sides in three screw directions

for universal and flexible gripper assembly

#### Air supply via hose-free direct connection or fittings

for the flexible supply of compressed air in all automation systems

#### M5 connection on both sides near the guides

for the use of lubricating nipples



### General information on the series

#### Working principle

Wedge-hook kinematics

#### Housing material

Aluminum alloy, hard-anodized

#### Base jaw material

Steel

#### Actuation

Pneumatic, with filtered compressed air (10 µm): Dry, lubricated or non-lubricated  
Pressure medium: Requirements on quality of the compressed air according to DIN ISO 8573-1: 6 4 4.

#### Warranty

24 months

#### Scope of delivery

Brackets for proximity switches, centering sleeves, O-rings for direct connection, Assembly and Operating Manual with manufacturer's declaration

#### Maintenance of gripping force

with either mechanical gripping force safety device or SDV-P pressure maintenance valve

### Sectional diagram

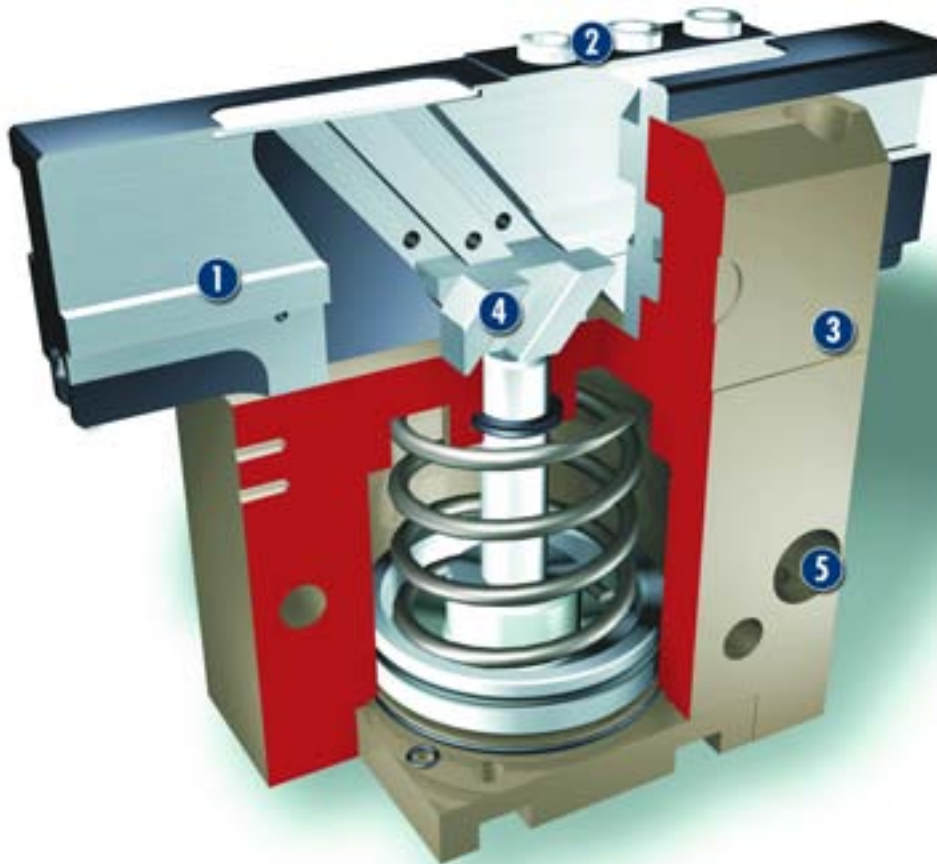

- 1 Guidance**  
precise gripping through flat, low-play precision ground guidance along the entire length of the housing
- 2 Base jaws**  
for the connection of workpiece-specific gripper fingers
- 3 Housing**  
weight-reduced through the use of a hard-anodized, high-strength aluminum alloy
- 4 Kinematics**  
wedge-hook principle for high power transmission and centric gripping
- 5 Centering and mounting possibilities**  
for universal gripper assembly

### Function description

The round piston is moved up or down by means of compressed air. Through its angled active surfaces, the wedge hook transforms this motion into the lateral, synchronous gripping movement of both base jaws.

### Options and special information

Due to the long guidance, the gripper is highly resistant during gripping operations when the gripper fingers are subject to high moment loads. Grippers with increased exchange accuracy are available on request.

**Accessories**

Accessories from SCHUNK – the suitable supplement for maximum functionality, reliability and performance of all automation modules.

**Centering sleeves**

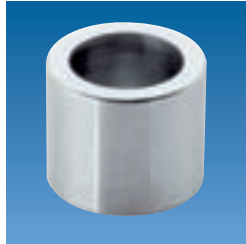

**Fittings**



**IN inductive proximity switches**

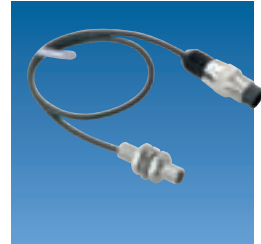

**Quentes plastic inserts**



**KV/KA sensor cables**



**HKI gripper pads**

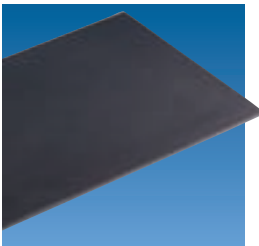

**V sensor distributors**



**SDV-P pressure maintenance valves**



**FPS flexible position sensor**

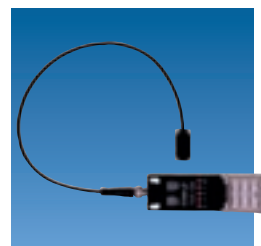

① For the exact size of the required accessories, availability of this size and the designation and ID, please refer to the additional views at the end of the size in question. You will find more detailed information on our accessory range in the „Accessories“ catalog section.

**General information on the series**

**Gripping force**

is the arithmetic total of the gripping force applied to each base jaw at distance P (see illustration), measured from the upper edge of the gripper.

**Finger length**

is measured from the upper edge of the gripper housing in the direction of the main axis.

**Repeat accuracy**

is defined as the spread of the limit position after 100 consecutive strokes.

**Workpiece weight**

The recommended workpiece weight is calculated for a force-type connection with a coefficient of friction of 0.1 and a safety factor of 2 against slippage of the workpiece on acceleration due to gravity g. Considerably heavier workpiece weights are permitted with form-fit gripping.

**Closing and opening times**

Closing and opening times are purely the times that the base jaws or fingers are in motion. Valve switching times, hose filling times or PLC reaction times are not included in the above times and must be taken into consideration when determining cycle times.



### Gripping force, I.D. gripping

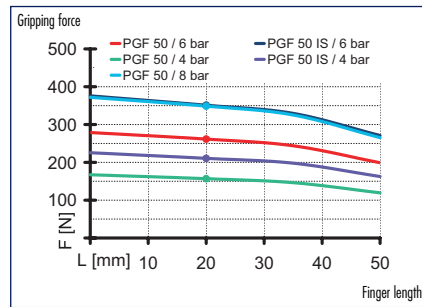

### Gripping force, O.D. gripping

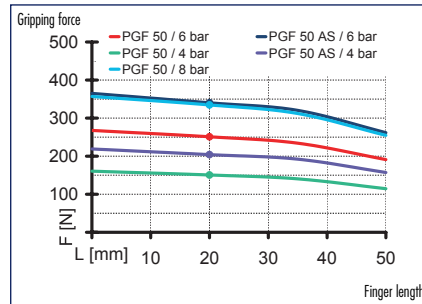

### Finger load

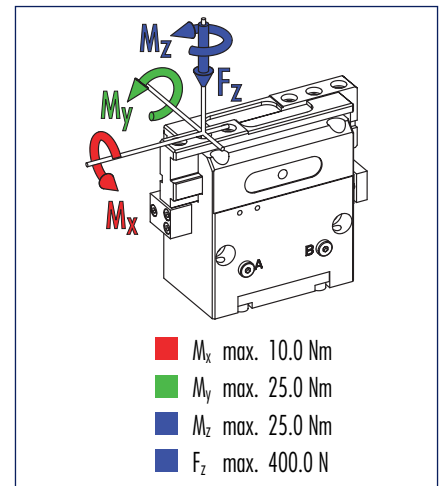

① Moments and forces apply per base jaw and may occur simultaneously.  $M_y$  may arise in addition to the moment generated by the gripping force itself. If the max. permitted finger weight is exceeded, it is imperative to throttle the air pressure so that the jaw movement occurs without any hitting or bouncing. Service life may reduce.

## Technical data

Description	ID	PGF 50	PGF 50-AS	PGF 50-IS
		0340360	0340361	0340362
Stroke per finger	[mm]	7.5	7.5	7.5
Closing force	[N]	240.0	340.0	
Opening force	[N]	260.0		360.0
Min. gripping force through spring	[N]		100.0	100.0
Weight	[kg]	0.3	0.35	0.35
Recommended workpiece weight	[kg]	1.2	1.2	1.2
Air consumption per double stroke	[cm <sup>3</sup> ]	14.0	14.0	14.0
Nominal pressure	[bar]	6.0	6.0	6.0
Minimum pressure	[bar]	3.5	4.0	4.0
Maximum pressure	[bar]	8.0	6.5	6.5
Closing time	[s]	0.03	0.03	0.07
Opening time	[s]	0.03	0.07	0.03
Closing/opening time with spring only	[s]		0.5	0.5
Max. permitted finger length	[mm]	50.0	50.0	50.0
Max. permitted weight per finger	[kg]	0.25	0.25	0.25
IP class		40	40	40
Min. ambient temperature	[°C]	-10.0	-10.0	-10.0
Max. ambient temperature	[°C]	90.0	90.0	90.0
Repeat accuracy	[mm]	0.02	0.02	0.02

### Main views

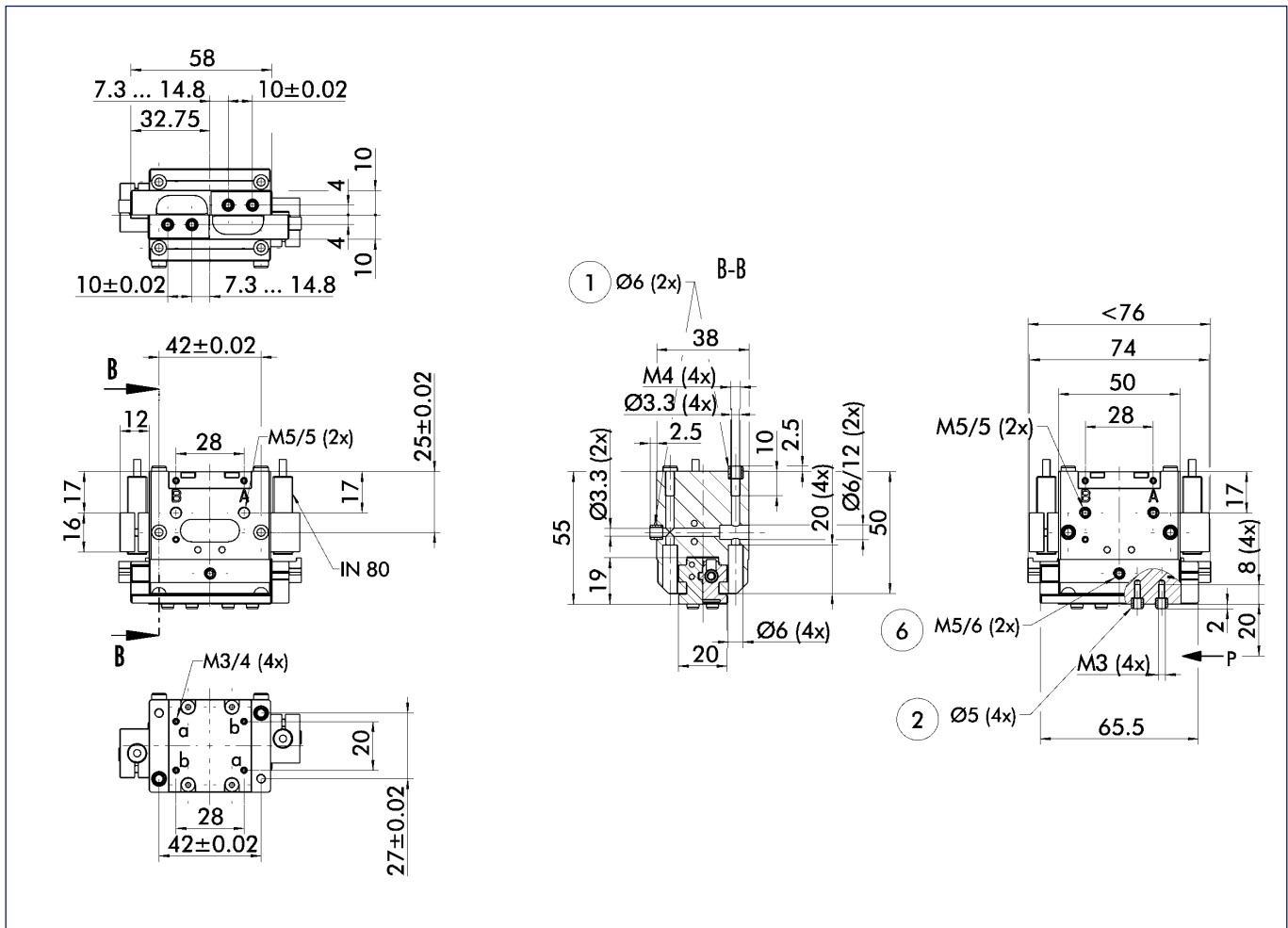

The drawing shows the gripper in the basic version with closed jaws, the dimensions do not include the options described below.

① The SDV-P pressure maintenance valve can also be used (see „Accessories“ catalog section) for I.D. or O.D. gripping as an alternative or in addition to the spring-loaded, mechanical gripping force safety device.

- A,a Main/direct connection, gripper opening
- B,b Main/direct connection, gripper closing
- ① Gripper connection
- ② Finger connection
- ⑥ Lubricating nipple connection

### Hose-free direct connection

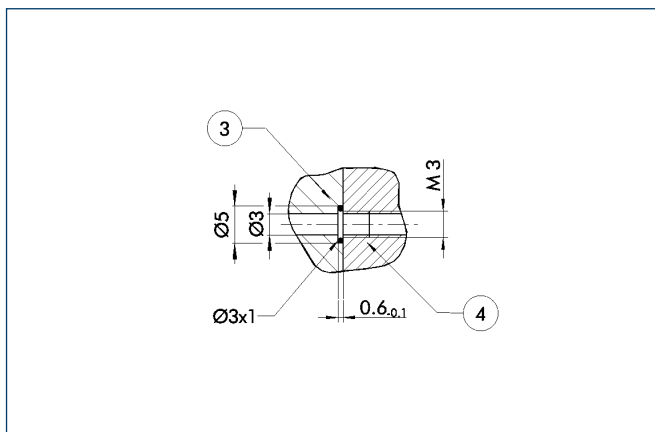

- ③ Adapter
- ④ Gripper

The direct connection is used for supplying compressed air to the gripper without hoses. Instead, the pressure medium is fed through bore-holes in the mounting plate.

### Mounting kit for FPS

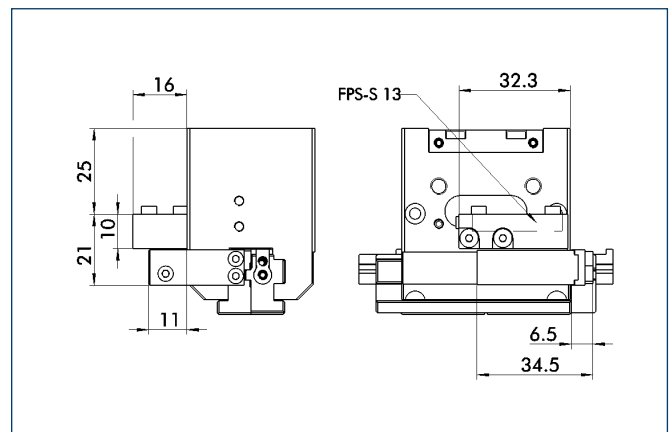

The FPS flexible position sensor can distinguish between five freely programmable ranges or switching points for the stroke of a gripper and can be used in conjunction with a PC as a measuring system.

Description	ID
AS-PGF 50	0302731

### Sensor system

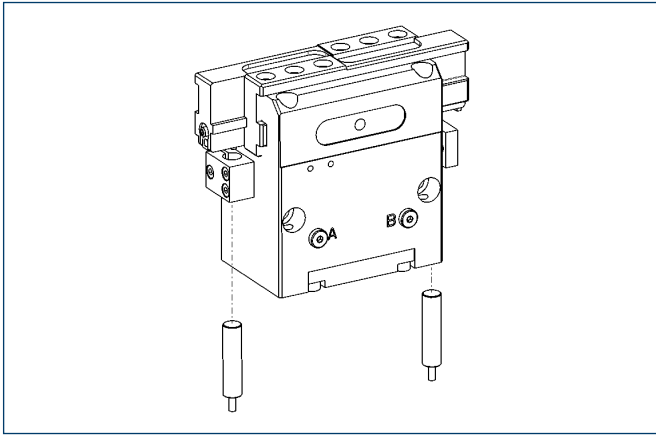

#### End position monitoring:

##### Inductive proximity switches, for direct mounting

Description	ID	Recommended product
IN 80-S-M12	0301578	
IN 80-S-M8	0301478	•
IN-C 80-S-M8	0301475	
INK 80-S	0301550	

① Two sensors (NO contacts) are required for each gripper, plus extension cables as an option.

#### Extension cables for proximity switches/magnetic switches

Description	ID
KA BG08-L 3P-0300-PNP	0301622
KA BW08-L 3P-0300-PNP	0301594
KA BW08-L 3P-0500-PNP	0301502
KA BW12-L 3P-0300-PNP	0301503
KA BW12-L 3P-0500-PNP	0301507
KV BW08-SG08 3P-0030-PNP	0301495
KV BW08-SG08 3P-0100-PNP	0301496
KV BW08-SG08 3P-0200-PNP	0301497
KV BW12-SG12 3P-0030-PNP	0301595
KV BW12-SG12 3P-0100-PNP	0301596
KV BW12-SG12 3P-0200-PNP	0301597

① Please note the minimum permitted bending radii for the sensor cables, which are generally 35 mm.



You can find more detailed information and individual parts of the above-mentioned accessories in the „Accessories“ catalog section.

### Sensor system

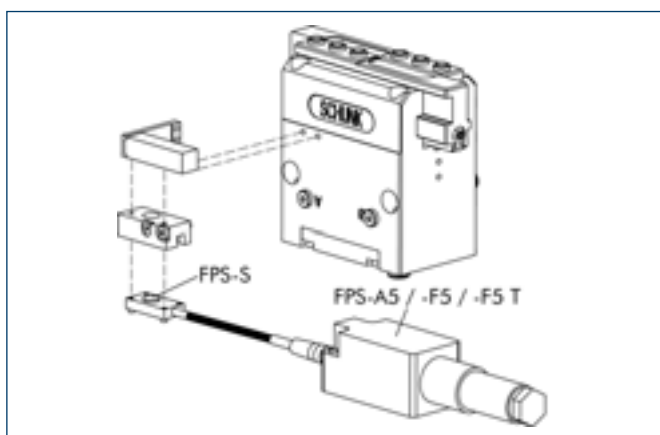

#### Measuring system:

#### FPS Flexible position sensor

Description	ID
AS-PGF 50	0302731
FPS-F5	0301805
FPS-F5 T	0301807
FPS-S 13	0301705

- ① When using an FPS system, an FPS sensor (FPS-S) and an control unit (FPS-F5 / F5 T or A5) are required for each gripper as well as a mounting kit (AS), if listed. Cable extensions (KV) are available as options in the „Accessories“ catalog section.





### Gripping force, I.D. gripping

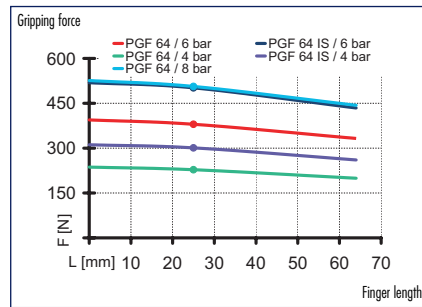

### Gripping force, O.D. gripping

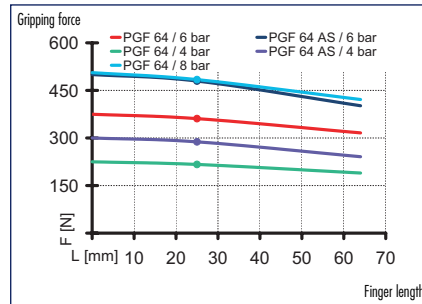

### Finger load

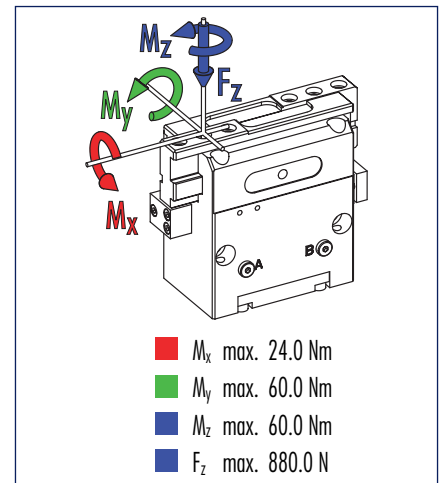

① Moments and forces apply per base jaw and may occur simultaneously.  $M_y$  may arise in addition to the moment generated by the gripping force itself. If the max. permitted finger weight is exceeded, it is imperative to throttle the air pressure so that the jaw movement occurs without any hitting or bouncing. Service life may reduce.

## Technical data

Description	ID	PGF 64	PGF 64-AS	PGF 64-IS
		0340365	0340366	0340367
Stroke per finger	[mm]	11.5	11.5	11.5
Closing force	[N]	360.0	480.0	
Opening force	[N]	380.0		500.0
Min. gripping force through spring	[N]		120.0	120.0
Weight	[kg]	0.6	0.7	0.7
Recommended workpiece weight	[kg]	1.8	1.8	1.8
Air consumption per double stroke	[cm <sup>3</sup> ]	30.0	30.0	30.0
Nominal pressure	[bar]	6.0	6.0	6.0
Minimum pressure	[bar]	3.5	4.0	4.0
Maximum pressure	[bar]	8.0	6.5	6.5
Closing time	[s]	0.06	0.05	0.1
Opening time	[s]	0.06	0.1	0.05
Closing/opening time with spring only	[s]		0.5	0.5
Max. permitted finger length	[mm]	64.0	64.0	64.0
Max. permitted weight per finger	[kg]	0.4	0.4	0.4
IP rating		40	40	40
Min. ambient temperature	[°C]	-10.0	-10.0	-10.0
Température ambiante max.	[°C]	90.0	90.0	90.0
Repeat accuracy	[mm]	0.02	0.02	0.02

### Main views

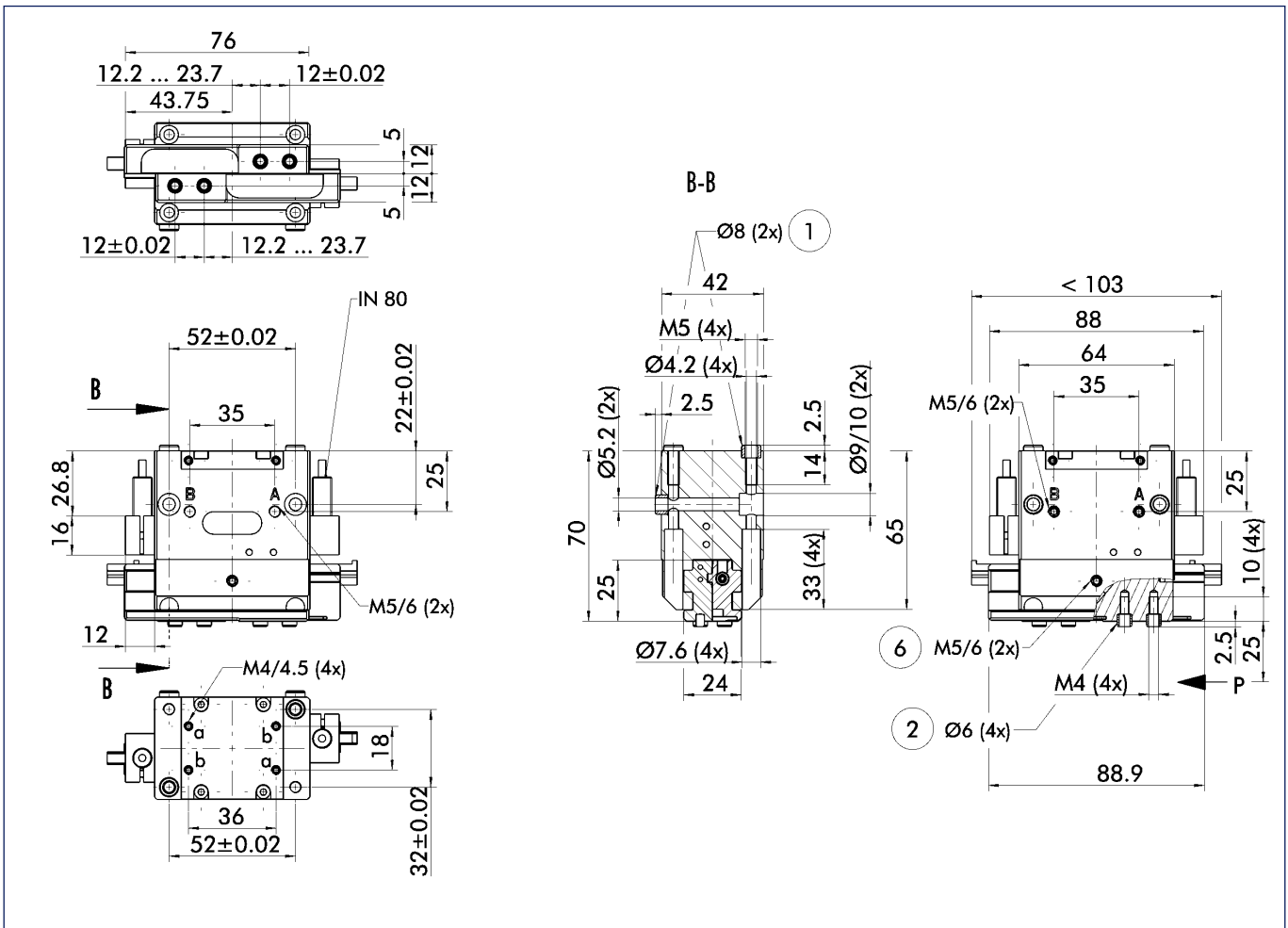

The drawing shows the gripper in the basic version with closed jaws, the dimensions do not include the options described below.

① The SDV-P pressure maintenance valve can also be used (see „Accessories“ catalog section) for I.D. or O.D. gripping as an alternative or in addition to the spring-loaded, mechanical gripping force safety device.

- A,a Main/direct connection, gripper opening
- B,b Main/direct connection, gripper closing
- ① Gripper connection
- ② Finger connection
- ⑥ Lubricating nipple connection

### Hose-free direct connection

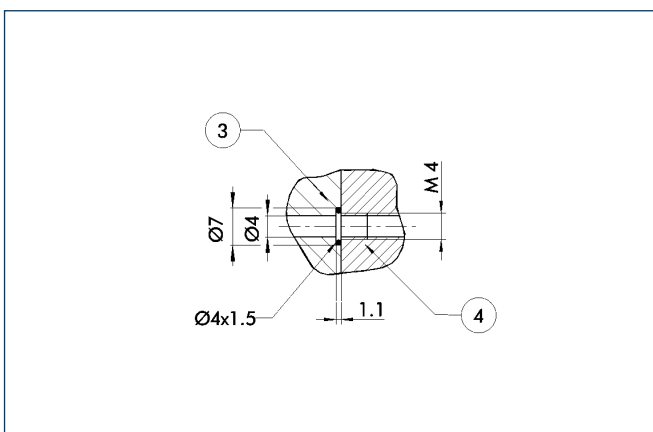

- ③ Adapter
- ④ Gripper

The direct connection is used for supplying compressed air to the gripper without hoses. Instead, the pressure medium is fed through bore-holes in the mounting plate.

### Mounting kit for FPS

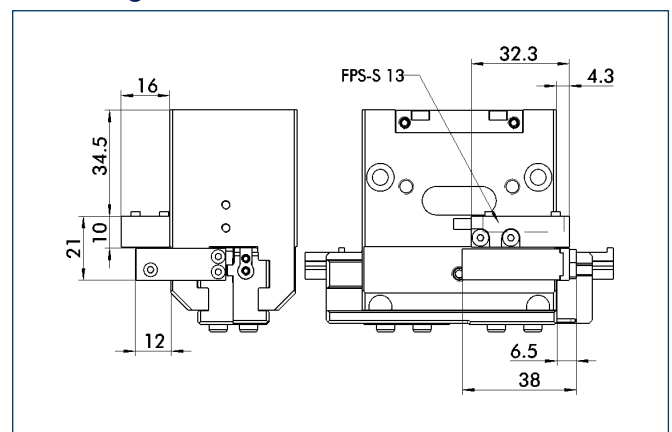

The FPS flexible position sensor can distinguish between five freely programmable ranges or switching points for the stroke of a gripper and can be used in conjunction with a PC as a measuring system.

Description	ID
AS-PGF 64	0302732

### Sensor system

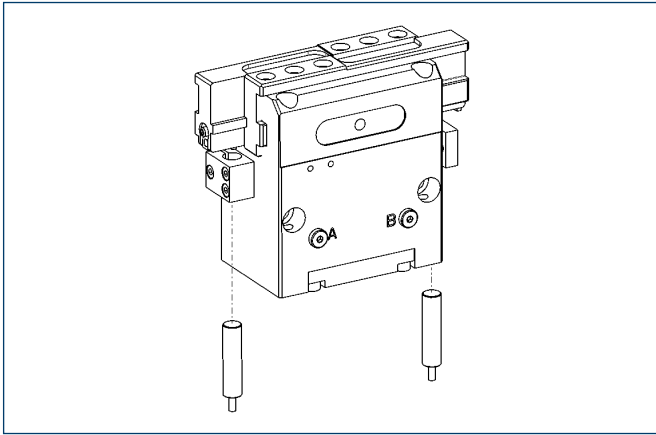

#### End position monitoring:

#### Inductive proximity switches, for direct mounting

Description	ID	Recommended product
IN 80-S-M12	0301578	
IN 80-S-M8	0301478	•
IN-C 80-S-M8	0301475	
INK 80-S	0301550	

① Two sensors (NO contacts) are required for each gripper, plus extension cables as an option.

#### Extension cables for proximity switches/magnetic switches

Description	ID
KA BG08-L 3P-0300-PNP	0301622
KA BW08-L 3P-0300-PNP	0301594
KA BW08-L 3P-0500-PNP	0301502
KA BW12-L 3P-0300-PNP	0301503
KA BW12-L 3P-0500-PNP	0301507
KV BW08-SG08 3P-0030-PNP	0301495
KV BW08-SG08 3P-0100-PNP	0301496
KV BW08-SG08 3P-0200-PNP	0301497
KV BW12-SG12 3P-0030-PNP	0301595
KV BW12-SG12 3P-0100-PNP	0301596
KV BW12-SG12 3P-0200-PNP	0301597

① Please note the minimum permitted bending radii for the sensor cables, which are generally 35 mm.



You can find more detailed information and individual parts of the above-mentioned accessories in the „Accessories“ catalog section.

### Sensor system

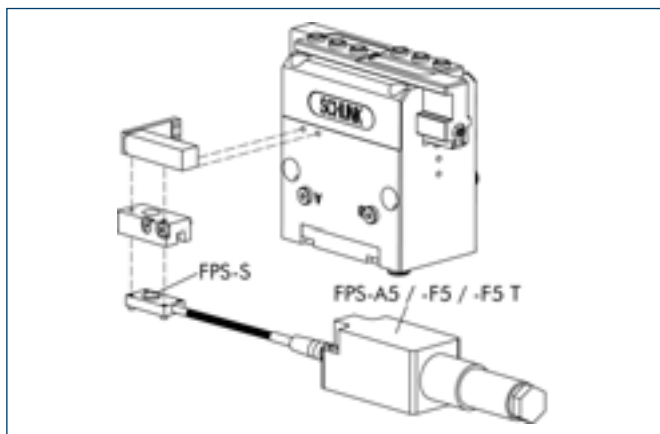

#### Measuring system:

#### FPS Flexible position sensor

Description	ID
AS-PGF 64	0302732
FPS-F5	0301805
FPS-F5 T	0301807
FPS-S 13	0301705

- ① When using an FPS system, an FPS sensor (FPS-S) and an control unit (FPS-F5 / F5 T or A5) are required for each gripper as well as a mounting kit (AS), if listed. Cable extensions (KV) are available as options in the „Accessories“ catalog section.



### Gripping force, I.D. gripping

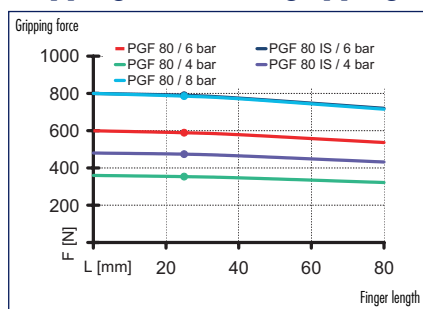

### Gripping force, O.D. gripping

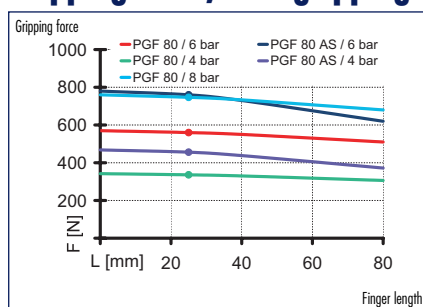

### Finger load

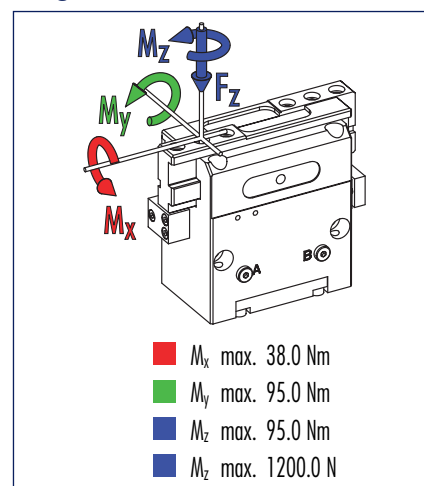

① Moments and forces apply per base jaw and may occur simultaneously.  $M_y$  may arise in addition to the moment generated by the gripping force itself. If the max. permitted finger weight is exceeded, it is imperative to throttle the air pressure so that the jaw movement occurs without any hitting or bouncing. Service life may reduce.

## Technical data

Description	ID	PGF 80	PGF 80-AS	PGF 80-IS
		0340370	0340371	0340372
Stroke per finger	[mm]	16.5	16.5	16.5
Closing force	[N]	560.0	760.0	
Opening force	[N]	590.0		790.0
Min. gripping force through spring	[N]		200.0	200.0
Weight	[kg]	1.15	1.25	1.25
Recommended workpiece weight	[kg]	2.8	2.8	2.8
Air consumption per double stroke	[cm <sup>3</sup> ]	77.0	77.0	77.0
Nominal pressure	[bar]	6.0	6.0	6.0
Minimum pressure	[bar]	3.5	4.0	4.0
Maximum pressure	[bar]	8.0	6.5	6.5
Closing time	[s]	0.1	0.08	0.14
Opening time	[s]	0.1	0.14	0.08
Closing/opening time with spring only	[s]		0.6	0.6
Max. permitted finger length	[mm]	80.0	80.0	80.0
Max. permitted weight per finger	[kg]	0.75	0.75	0.75
IP rating		40	40	40
Min. ambient temperature	[°C]	-10.0	-10.0	-10.0
Température ambiante max.	[°C]	90.0	90.0	90.0
Repeat accuracy	[mm]	0.02	0.02	0.02

### Main views

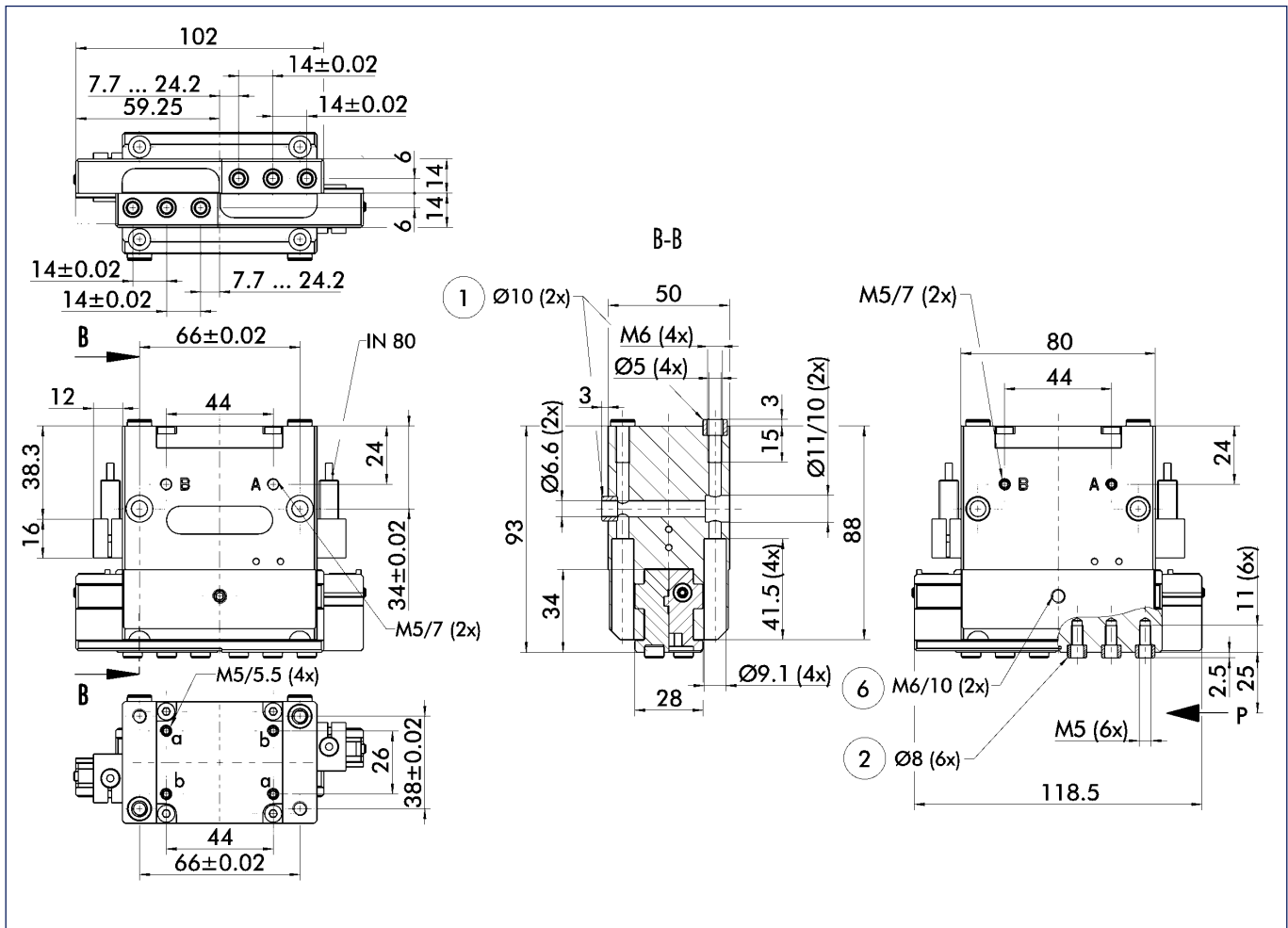

The drawing shows the gripper in the basic version with closed jaws, the dimensions do not include the options described below.

① The SDV-P pressure maintenance valve can also be used (see „Accessories“ catalog section) for I.D. or O.D. gripping as an alternative or in addition to the spring-loaded, mechanical gripping force safety device.

- A,a Main/direct connection, gripper opening
- B,b Main/direct connection, gripper closing
- ① Gripper connection
- ② Finger connection
- ⑥ Lubricating nipple connection

### Hose-free direct connection

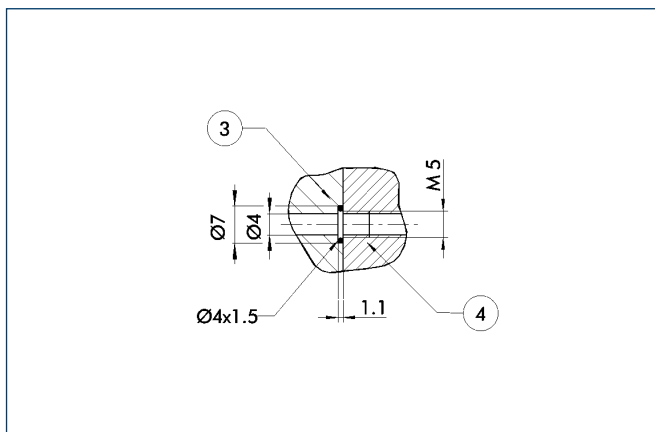

- ③ Adapter
- ④ Gripper

The direct connection is used for supplying compressed air to the gripper without hoses. Instead, the pressure medium is fed through bore-holes in the mounting plate.

### Mounting kit for FPS

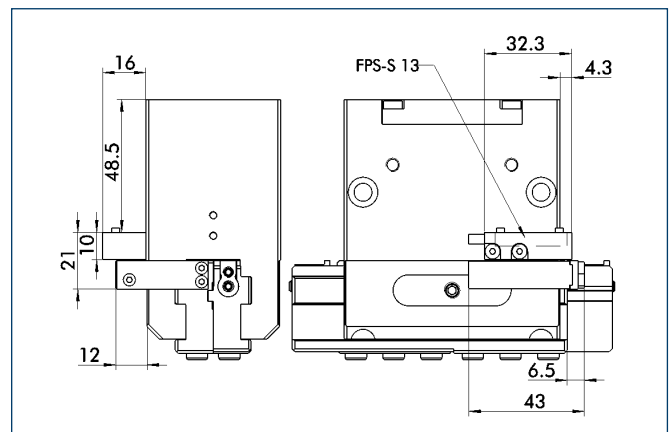

The FPS flexible position sensor can distinguish between five freely programmable ranges or switching points for the stroke of a gripper and can be used in conjunction with a PC as a measuring system.

Description	ID
AS-PGF 80	0302733

### Sensor system

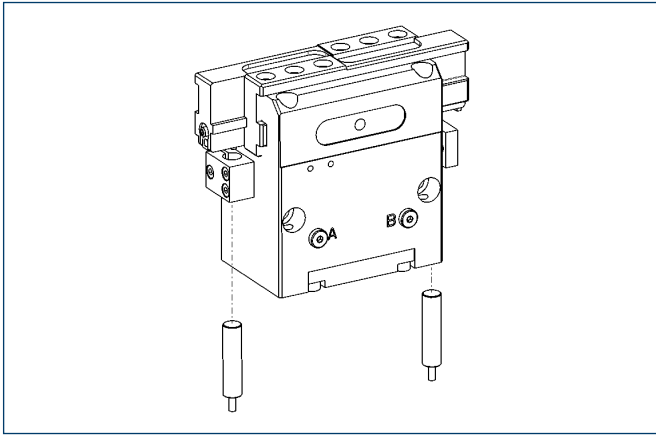

#### End position monitoring:

#### Inductive proximity switches, for direct mounting

Description	ID	Recommended product
IN 80-S-M12	0301578	
IN 80-S-M8	0301478	•
IN-C 80-S-M8	0301475	
INK 80-S	0301550	

① Two sensors (NO contacts) are required for each gripper, plus extension cables as an option.

#### Extension cables for proximity switches/magnetic switches

Description	ID
AS-PGF 80	0302733
FPS-F5	0301805
FPS-F5 T	0301807
FPS-S 13	0301705

① Please note the minimum permitted bending radii for the sensor cables, which are generally 35 mm.



You can find more detailed information and individual parts of the above-mentioned accessories in the „Accessories“ catalog section.

### Sensor system

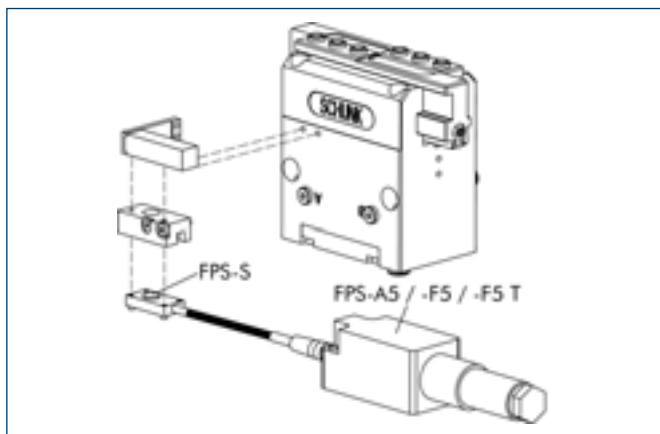

#### Measuring system:

#### FPS Flexible position sensor

Description	ID
AS-PGF 80	0302733
FPS-F5	0301805
FPS-F5 T	0301807
FPS-S 13	0301705

- ① When using an FPS system, an FPS sensor (FPS-S) and an control unit (FPS-F5 / F5 T or A5) are required for each gripper as well as a mounting kit (AS), if listed. Cable extensions (KV) are available as options in the „Accessories“ catalog section.



# PGF 100

Pneumatic · 2-Finger Parallel Gripper · **Universal Gripper**



## Gripping force, I.D. gripping

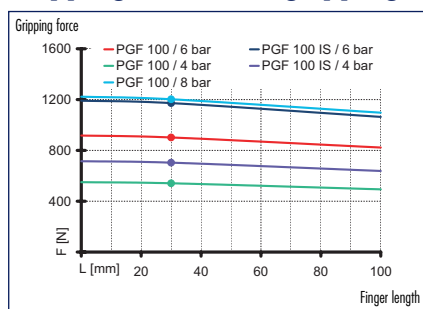

## Gripping force, O.D. gripping

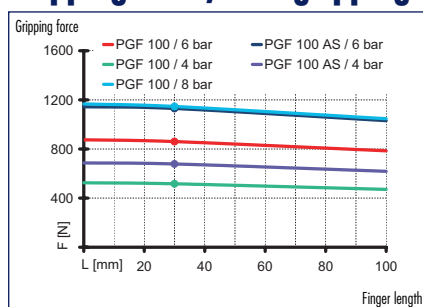

## Finger load

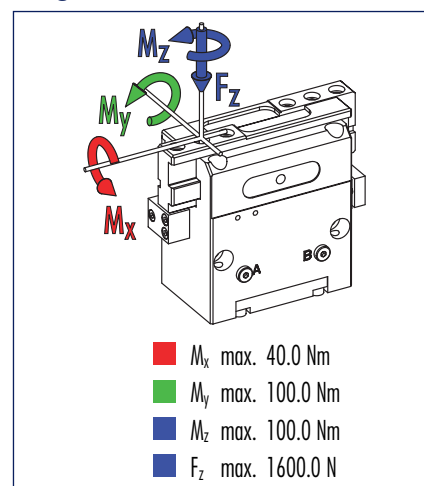

① Moments and forces apply per base jaw and may occur simultaneously.  $M_y$  may arise in addition to the moment generated by the gripping force itself. If the max. permitted finger weight is exceeded, it is imperative to throttle the air pressure so that the jaw movement occurs without any hitting or bouncing. Service life may reduce.

## Technical data

Description		PGF 100	PGF 100-AS	PGF 100-IS
	ID	0340380	0340381	0340382
Stroke per finger	[mm]	23.5	23.5	23.5
Closing force	[N]	880.0	1150.0	
Opening force	[N]	900.0		1170.0
Min. gripping force through spring	[N]		270.0	270.0
Weight	[kg]	2.35	2.85	2.85
Recommended workpiece weight	[kg]	4.4	4.4	4.4
Air consumption per double stroke	[cm <sup>3</sup> ]	154.0	154.0	154.0
Nominal pressure	[bar]	6.0	6.0	6.0
Minimum pressure	[bar]	3.5	4.0	4.0
Maximum pressure	[bar]	8.0	6.5	6.5
Closing time	[s]	0.15	0.16	0.25
Opening time	[s]	0.15	0.25	0.16
Closing/opening time with spring only	[s]		0.7	0.7
Max. permitted finger length	[mm]	100.0	100.0	100.0
Max. permitted weight per finger	[kg]	1.4	1.4	1.4
IP rating		40	40	40
Min. ambient temperature	[°C]	-10.0	-10.0	-10.0
Température ambiante max.	[°C]	90.0	90.0	90.0
Repeat accuracy	[mm]	0.03	0.03	0.03



### Sensor system

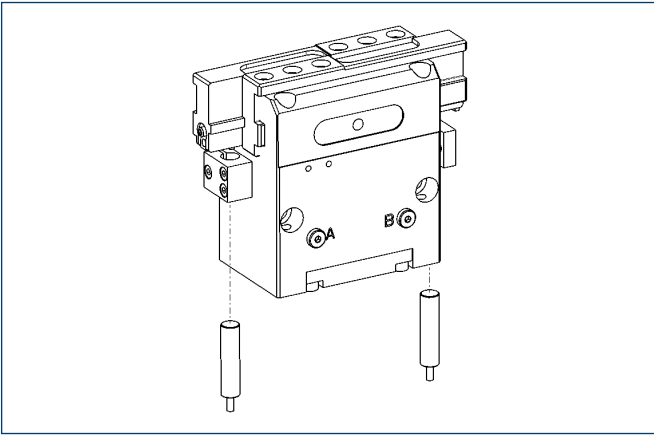

#### End position monitoring:

#### Inductive proximity switches, for direct mounting

Description	ID	Recommended product
IN 80-S-M12	0301578	
IN 80-S-M8	0301478	•
IN-C 80-S-M8	0301475	
INK 80-S	0301550	

① Two sensors (NO contacts) are required for each gripper, plus extension cables as an option.

#### Extension cables for proximity switches/magnetic switches

Description	ID
KA BG08-L 3P-0300-PNP	0301622
KA BW08-L 3P-0300-PNP	0301594
KA BW08-L 3P-0500-PNP	0301502
KA BW12-L 3P-0300-PNP	0301503
KA BW12-L 3P-0500-PNP	0301507
KV BW08-SG08 3P-0030-PNP	0301495
KV BW08-SG08 3P-0100-PNP	0301496
KV BW08-SG08 3P-0200-PNP	0301497
KV BW12-SG12 3P-0030-PNP	0301595
KV BW12-SG12 3P-0100-PNP	0301596
KV BW12-SG12 3P-0200-PNP	0301597

① Please note the minimum permitted bending radii for the sensor cables, which are generally 35 mm.



You can find more detailed information and individual parts of the above-mentioned accessories in the „Accessories“ catalog section.

### Sensor system

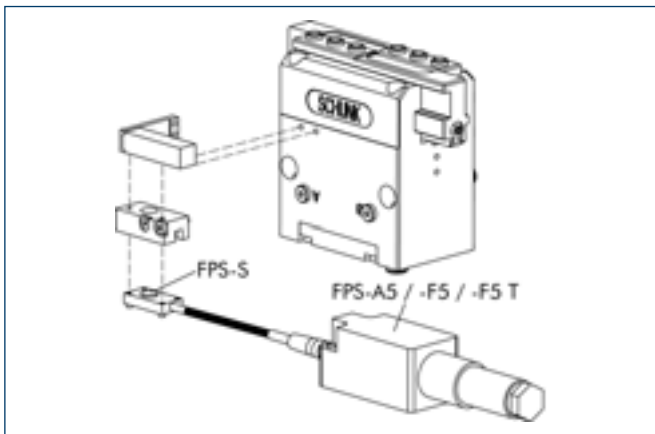

#### Measuring system:

#### FPS Flexible position sensor

Description	ID
AS-PGF 100	0302734
FPS-F5	0301805
FPS-F5 T	0301807
FPS-S 13	0301705

- ① When using an FPS system, an FPS sensor (FPS-S) and an control unit (FPS-F5 / F5 T or A5) are required for each gripper as well as a mounting kit (AS), if listed. Cable extensions (KV) are available as options in the „Accessories“ catalog section.



You can find more detailed information and individual parts of the above-mentioned accessories in the „Accessories“ catalog section.

# PGF 125

Pneumatic · 2-Finger Parallel Gripper · **Universal Gripper**



## Gripping force, I.D. gripping

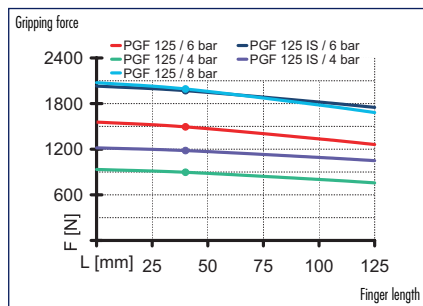

## Gripping force, O.D. gripping

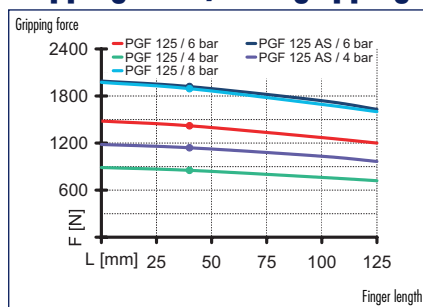

## Finger load

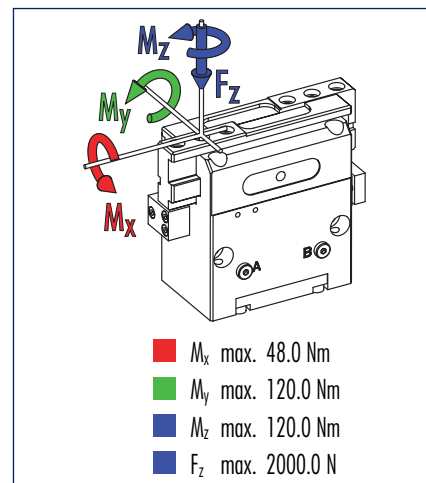

ⓘ Moments and forces apply per base jaw and may occur simultaneously.  $M_y$  may arise in addition to the moment generated by the gripping force itself. If the max. permitted finger weight is exceeded, it is imperative to throttle the air pressure so that the jaw movement occurs without any hitting or bouncing. Service life may reduce.

## Technical data

Description	PGF 125		PGF 125-AS	PGF 125-IS
	ID	0340390	0340391	0340392
Stroke per finger	[mm]	31.5	31.5	31.5
Closing force	[N]	1420.0	1900.0	
Opening force	[N]	1490.0		1970.0
Min. gripping force through spring	[N]		480.0	480.0
Weight	[kg]	5.0	5.3	5.3
Recommended workpiece weight	[kg]	7.1	7.1	7.1
Air consumption per double stroke	[cm <sup>3</sup> ]	300.0	300.0	300.0
Nominal pressure	[bar]	6.0	6.0	6.0
Minimum pressure	[bar]	3.5	4.0	4.0
Maximum pressure	[bar]	8.0	6.5	6.5
Closing time	[s]	0.25	0.22	0.4
Opening time	[s]	0.25	0.4	0.22
Closing/opening time with spring only	[s]		0.8	0.8
Max. permitted finger length	[mm]	125.0	125.0	125.0
Max. permitted weight per finger	[kg]	2.4	2.4	2.4
IP rating		40	40	40
Min. ambient temperature	[°C]	-10.0	-10.0	-10.0
Température ambiante max.	[°C]	90.0	90.0	90.0
Repeat accuracy	[mm]	0.03	0.03	0.03

### Main views

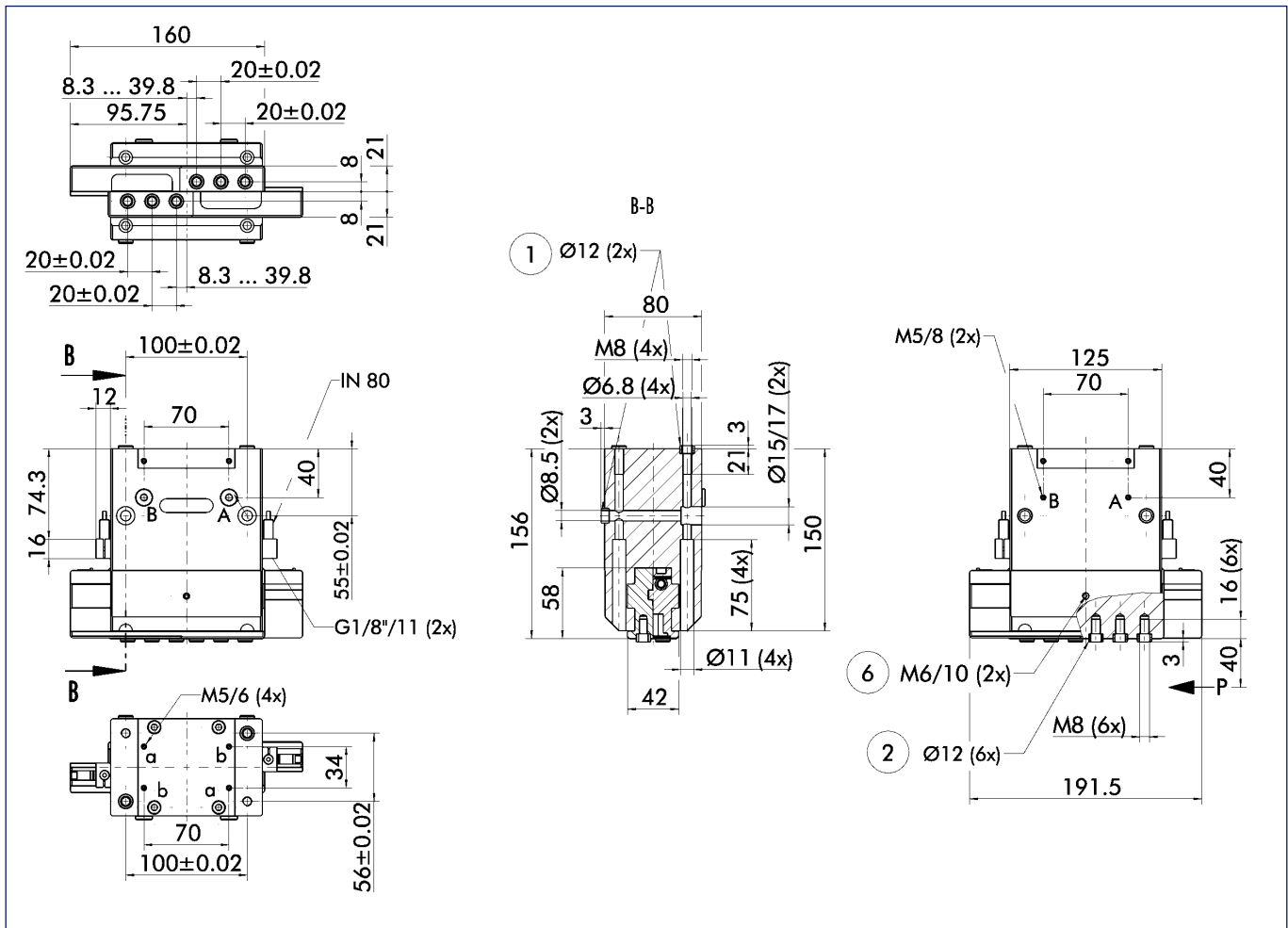

The drawing shows the gripper in the basic version with closed jaws, the dimensions do not include the options described below.

① The SDV-P pressure maintenance valve can also be used (see „Accessories“ catalog section) for I.D. or O.D. gripping as an alternative or in addition to the spring-loaded, mechanical gripping force safety device.

- A,a Main/direct connection, gripper opening
- B,b Main/direct connection, gripper closing
- ① Gripper connection
- ② Finger connection
- ⑥ Lubricating nipple connection

### Hose-free direct connection

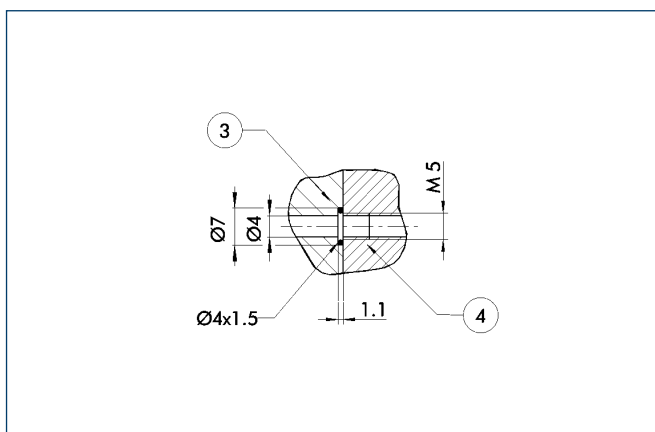

- ③ Adapter
- ④ Gripper

The direct connection is used for supplying compressed air to the gripper without hoses. Instead, the pressure medium is fed through bore-holes in the mounting plate.

### Sensor system

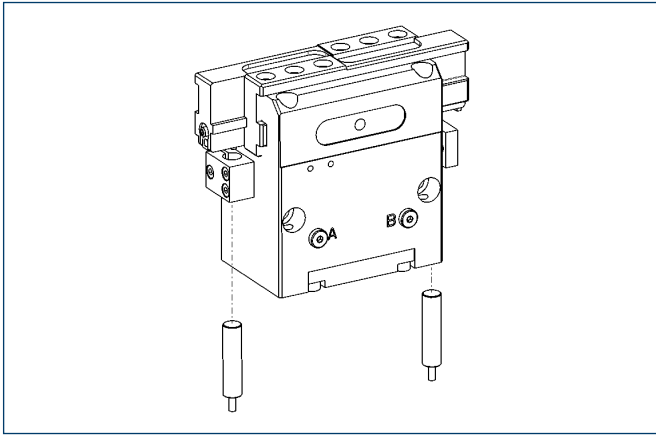

#### End position monitoring:

#### Inductive proximity switches, for direct mounting

Description	ID	Recommended product
IN 80-S-M12	0301578	
IN 80-S-M8	0301478	•
IN-C 80-S-M8	0301475	
INK 80-S	0301550	

① Two sensors (NO contacts) are required for each gripper, plus extension cables as an option.

#### Extension cables for proximity switches/magnetic switches

Description	ID
KA BG08-L 3P-0300-PNP	0301622
KA BW08-L 3P-0300-PNP	0301594
KA BW08-L 3P-0500-PNP	0301502
KA BW12-L 3P-0300-PNP	0301503
KA BW12-L 3P-0500-PNP	0301507
KV BW08-SG08 3P-0030-PNP	0301495
KV BW08-SG08 3P-0100-PNP	0301496
KV BW08-SG08 3P-0200-PNP	0301497
KV BW12-SG12 3P-0030-PNP	0301595
KV BW12-SG12 3P-0100-PNP	0301596
KV BW12-SG12 3P-0200-PNP	0301597

① Please note the minimum permitted bending radii for the sensor cables, which are generally 35 mm.



You can find more detailed information and individual parts of the above-mentioned accessories in the „Accessories“ catalog section.