

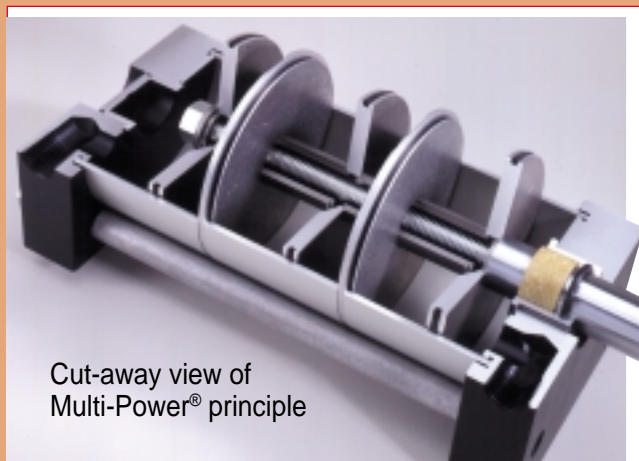

Multi-Power[®] Air Presses

*Step up to the Power,
Precision and Clean
Operation of Air*



Cut-away view of
Multi-Power[®] principle



Multi-Power[®] Air Presses

Provisions for operator protection are always the full responsibility of the user

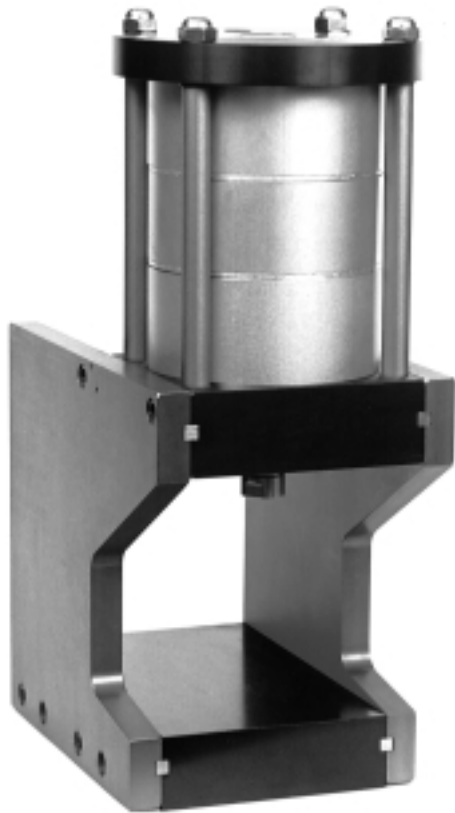

Shown: Model F55 - A x 1 - 10

Combining the muscle needed for production with the precision required for laboratory use

Fabco-Air applies the unique Multi-Power[®] Principle to a precision framework and base, providing you with the ultimate in a powerful, precision, compact, air-powered bench press for production or laboratory use.

How it works

The power cylinder uses multiple pistons attached to a common shaft. Each piston is isolated within its own chamber by means of baffles integral with the outer cylinder wall. Special internal porting allows air pressure to simultaneously energize all pistons – enabling output forces in excess of 5 tons to be easily reached!

How it's built

The power cylinder has all the standard Multi-Power[®] features plus beefed up construction to meet the rigors of press type applications–

- Hard chrome plated stainless steel ram
- Extended rod bearing length

- Duralon[®] rod bearing
- 3/8 NPT ports are standard, with generous internal passages for air flow to allow high cycling speeds
- High strength aluminum frame plates are machined on the edges and have precision-located keyways
- Plated steel keys mate the cylinder head and base plate to the frame plates, providing accurate alignment and rigid construction

The keyed and bolted, high-strength construction provides you with precision and long press life unobtainable from any other "C" frame or post type construction.

It's shipped ready for fast set-up
You get your Power Cylinder completely assembled with all ordered options. The Frame Plates, Base, Keys and Frame Bolts are packed un-assembled.

Only a few minutes are required for you to bolt the keyed components together.

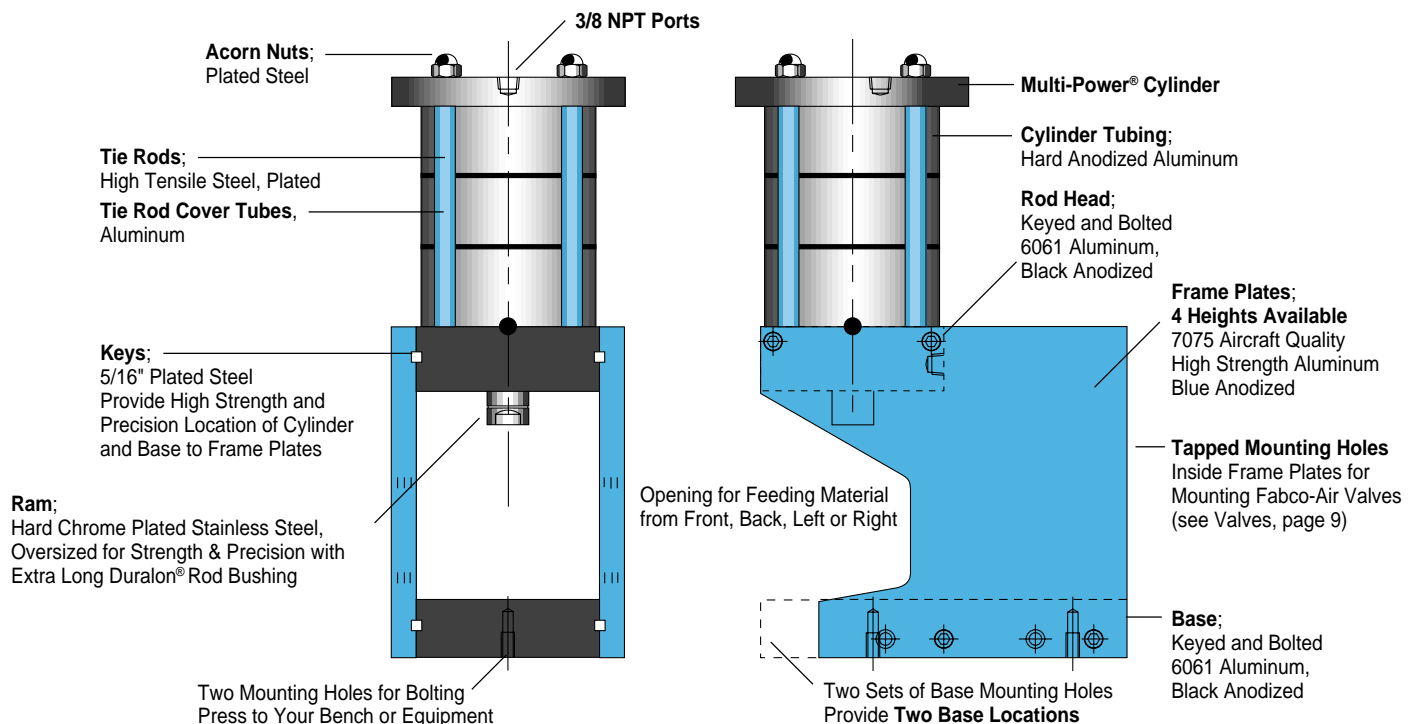

Delivering forces up to 11,000 pounds with Shop Air!

Provisions for operator protection are always the full responsibility of the user

A compact, powerful and versatile tool

Use it in unlimited applications in metals, plastics, ceramics, leather, etc.

- Multi-Power® Presses are economical and easily adapted to your needs
- Light weight and portable
- Easily located at the work site
- Small footprint requires less mounting space and requires less of your machine or bench space
- High force combined with low impact saves tooling
- Power return is strong enough to strip dies and/or lift heavy tooling
- Accuracy is ensured with an extra long Duralon® ram guide bearing
- Repeatability: Dial-A-Stroke® design provides rigid, precise control
- All air operation is clean. No hydraulics to contaminate clean rooms or laboratories
- Adjustable base makes the press easy to tool and do change-overs
- Replaceable base enables you to mount tooling and change over quickly for short run jobs
- Open front-to-back and left-to-right simplifies tooling and set up
- Easy and accurate force adjustment (See explanation at top right)
- Low maintenance
- Saves air consumption

Put it to work on these applications:

Riveting	Bending	Punching
Nibbling	Lancing	Notching
Blanking	Shearing	Coining
Marking	Skiving	Piercing
Broaching	Squeezing	Crimping
Pressing in	Pressing out	Straightening
Assembly	Clamping	Embossing
Forming	and much more. . .	

An easy, economical way to accurately determine force requirements for your application

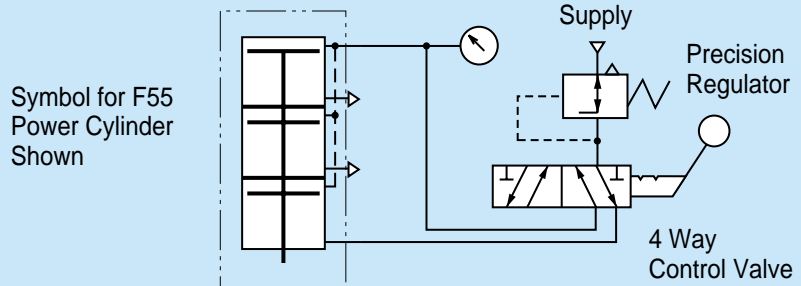

Application: How much force does it take to press a bearing into its housing or to crimp a piece of tubing?

1. Adjust regulator to zero pressure.
2. Situate application under ram.
3. Shift valve to ram down position.
4. Slowly adjust regulator to raise pressure.
5. Ram will move down to application.
6. Continue increasing pressure while watching application.
7. At the moment application is completed, read pressure gauge.
8. Multiply gauge pressure by effective piston area of your press (find piston areas in the "Power Cylinder Selection Guide", page 4)
9. Result is the force (lb.) required by your application.

Pressure (Force) Sensing Control

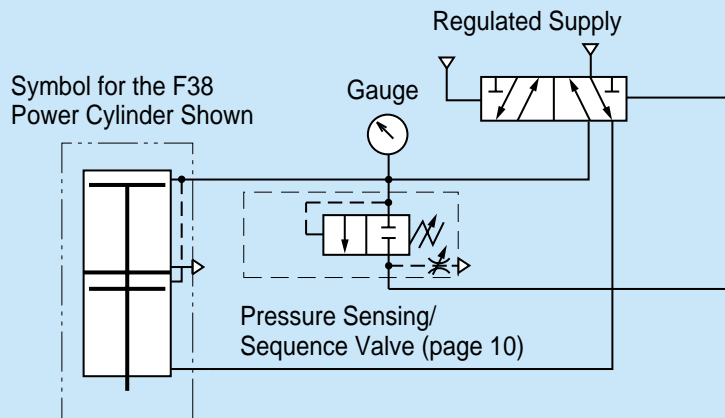

When the press force application (pressure) is sensed and controlled by Fabco-Air's Pressure Sensing/Sequence Valve (see description, page 10), the press will apply a pre-selected (adjustable) force and automatically retract.

This provides extremely accurate control for applications such as crimping, coining, assembly, etc.

It also provides **automatic quality control**.

If the supply pressure should fall below the Sensing Valve setting, the valve will not provide a "ram up" signal to the press. And the press will stall without making a bad crimp or ruining the part.

Once pressure is restored, the cycle will continue. The part that had been under the stalled ram will be finished as a "good part".

The pressure gauge confirms the sensed pressure.

Multi-Power[®] Air Presses

Provisions for operator protection are always the full responsibility of the user

Multi-Power[®] Press Configurations

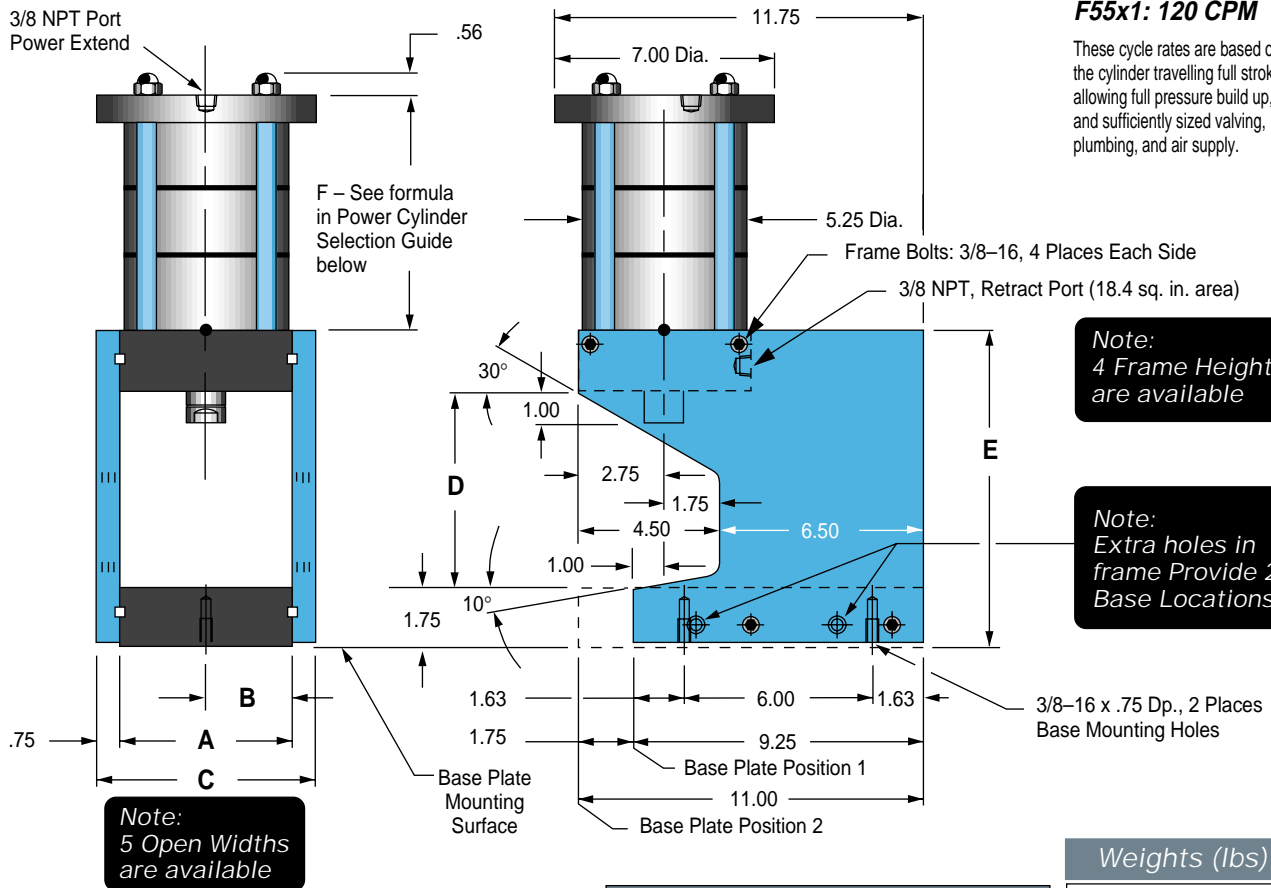

SPEED
F38x1: 140 CPM
F55x1: 120 CPM

These cycle rates are based on the cylinder travelling full stroke, allowing full pressure build up, and sufficiently sized valving, plumbing, and air supply.

Note: 4 Frame Heights are available

Note: Extra holes in frame Provide 2 Base Locations

Weights (lbs)	
Frame, Keys & Bolts	
10"	13.6
14"	18.0
16"	20.0
18"	22.0
Bases	
5-1/2"	8.6
7"	11.0
9"	14.1
10"	15.7
11"	17.2

Power Cyl. Weights (lbs) for 5-1/2" Open Width		
Power Cyl. No.	O Stroke Weight	+ Weight Per inch
F19	14.4	0.9
F38	16.5	1.5
F55	18.6	2.1
F72	20.7	2.7
F93	22.8	3.3

For other Open Widths
 if 7", add 1.7 lbs.
 if 9", add 3.9 lbs.
 if 10", add 5.0 lbs.
 if 11", add 6.1 lbs.

Dimensional Data

Open Widths Available					
DIM	5-1/2	7	9	10	11
A	5.50	7.00	9.00	10.00	11.00
B	2.75	3.50	4.50	5.00	5.50
C	7.00	8.50	10.50	11.50	12.50

Frame Plate Height				
DIM	10	14	16	18
D	6.31	10.31	12.31	14.31
E	10.00	14.00	16.00	18.00

Power Cylinder Selection Guide & "F" Dimension Formula

	F19	F38	F55	F72	F93
Formulas for "F" Dimension	Stroke + 2.22	2 x Stroke + 3.35	3 x Stroke + 4.47	4 x Stroke + 5.60	5 x Stroke + 6.72
Total effective piston area †	19.6 sq in	38.0 sq in	56.4 sq in	74.8 sq in	93.2 sq in
Maximum operating Pressure	150 psi	150 psi	150 psi	150 psi * 110 psi ‡	120 psi * 90 psi ‡
Force @ max. oper. pressure	2940 lb	5700 lb	8460 lb	11,220 lb * 8,228 lb ‡	11,184 lb * 8388 lb ‡
Force output = effective piston area x operating pressure Force for retracting ram = 18.4 sq in x operating pressure	† For -AS Option, area is reduced by 1.2 Sq. in.		*For open widths: 5-1/2" & 7" ‡ For open widths 9", 10", 11"		

Product Configurations & Ordering Information

Provisions for operator protection are always the full responsibility of the user

Power Cylinder Units

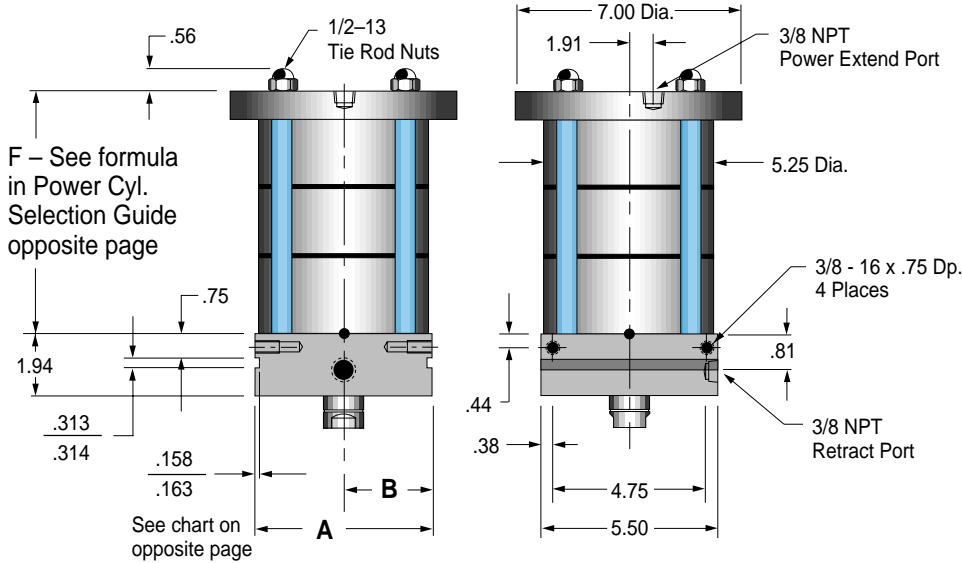

Other Multi-Power® cylinders from 1-1/8" thru 12" bores to 12" stroke are available if you want to build your own press. See page 11 or section 5 in Catalog #CV8.

Universal O'Ring Seal Kits

Buna N	Viton
F19-SK	F19-SKV
F38-SK	F38-SKV
F55-SK	F55-SKV
F72-SK	F72-SKV
F93-SK	F93-SKV

Order Seals for Option -HS as a separate item as shown below.

Seal Kits for Option -HS

Speed & Shock Control Seal Kit	
Buna N	Viton
FHS-SK	FHS-SKV

Standard Female Rod End

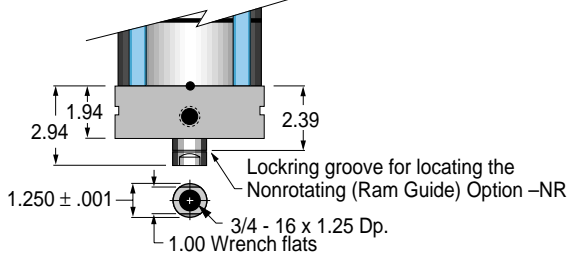

Model Number Code

F55	-	A	x	2	-	14	-	MR
Power Cylinder		Open Width		Stroke, Inches		Frame Plate Height		
F19		5-1/2" A		Standard		10		
F38		7" B		1"		14		
F55		9" C		increments through 6"		16		
F72‡		10" D		Optional		18		
F93‡		11" E		0" thru 12"				

How to Order an Air Press

1. Specify Power Cylinder
2. Specify Open Width
3. Specify Stroke
4. Specify Frame Plate Height
5. Specify Options

Order sensors, brackets, tanks, control valves and other accessories as separate items.

Example:

F55 - A x 2 - 14 - MR

55 Sq. in. effective piston area, 5-1/2" Open Width, 2" stroke, 14" high frame plates and Male Rod Thread.

How to Order a Power Cylinder Only

1. Specify Power Cylinder
2. Specify Open Width
3. Specify Stroke
4. Specify Options

Example:

F38 - B x 1 - C

38 Sq. in. effective piston area, 7" Open Width, 1" stroke, and Rubber Bumper on Rod End.

Options (See details on pages 6 - 8)

Specify

Nonrotating Rod (Ram Guide)	-NR
Male Rod Thread	-MR
Viton Seals	-V
Speed & Shock Control with hydraulics (‡ †)	-HS
Rubber Bumpers: Rod End	-C
Cap End	-BR
Both Ends	-CBR
Adjustable Extend Stroke up to 6" Stroke Maximum	-AS
Full stroke adjustment is standard.	
1/2 NPT Ports: Retract Port	-R12
Extend Port	-E12
Both Ports	-P12
High Flow Vents	-HF
Magnetic Piston for position sensing (†):	-E

(†) Additional cylinder length required

(‡) Some pressure restrictions apply

Multi-Power[®] Air Presses

Provisions for operator protection are always the full responsibility of the user

Viton Seals

Option -V

For elevated temperatures (-15° to +400° F) or compatibility with exotic media. Consult engineering for compatibility information.

Male Rod Thread

Option -MR

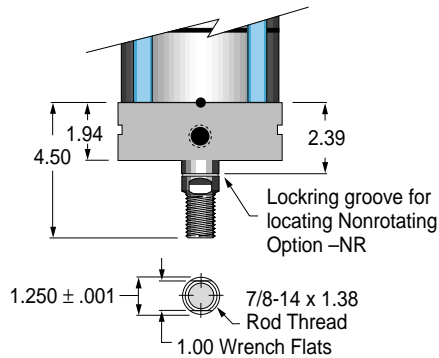

The thread is accurately machined onto the rod for precise alignment and extra strength. Fine pitch enables precise adjustment with room for a jam nut to lock tooling in place. The rod end is machined so tooling can be bottomed out if desired.

Nonrotating Rod (Ram Guide)

Option -NR

The nonrotating option keeps the piston rod and any attached tooling from rotating as the cylinder strokes. It consists of:

- Clamp – attaches to the piston rod.
- Guide Pin – a precision dowel pin.
- Yoke – hard anodized Aluminum. The yoke can be adjusted for any tolerances or wear occurring between the yoke and guide pin.
- Associated hardware.

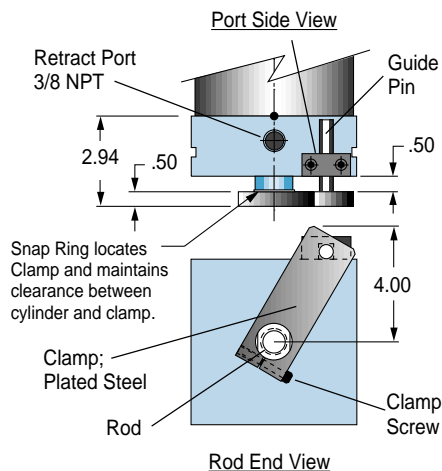

This option may be added at any time without disassembly of the cylinder.

Adjustable Extend Stroke

Option -AS

For strokes through 6" maximum. Full stroke adjustment is standard.

Note:

Deduct 1.2 square inches from the effective piston area.

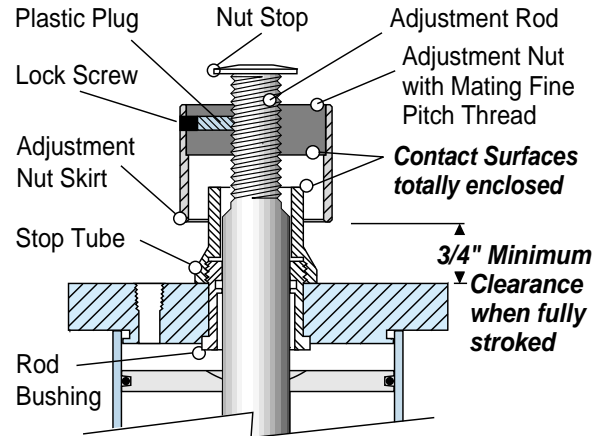

One Revolution of the Adjustment Nut adjusts the stroke by .071 inches. Adjustment settings are simplified by convenient scale markings applied to nut skirt and stop tube.

Dial-A-Stroke[®] provides a rugged, precision adjustment of the cylinder's extend stroke. The stop tube, adjustment nut with skirt, and minimum clearances combine to eliminate pinch points.

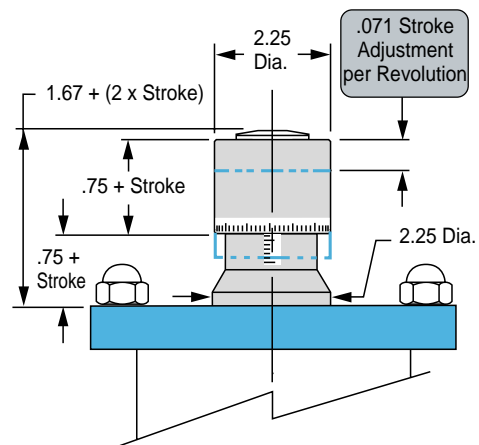

The stop tube is blue anodized aluminum • the adjustment nut is blackened steel with a black anodized aluminum skirt • the stop nut is red anodized aluminum: all for corrosion resistance and appearance. • The adjustment nut, steel for long life, includes a lock screw with a plastic plug so that the adjustment nut can be locked in place without damaging the threads. • The stop nut is mounted on the end of the adjustment rod so that the nut cannot come off. The fine pitch threads on the adjustment rod and nut provide precision adjustment.

Option Specifications

Provisions for operator protection are always the full responsibility of the user

High Flow Vents Option -HF

The atmospheric vent in the baffle is cut larger to provide less resistance to air flow. This option is used when higher cycle speeds are required.

Rubber Bumpers

Rod End Only Option -C
 Cap End Only Option -BR
 Both Ends Option -CBR

Temperature Range is -25° to + 200°F

A ring of rubber is bonded to the top cylinder head to act as the piston stop and absorb the impact of the piston. This minimizes noise and absorbs energy, thus reducing possibilities of damage to the cylinder and tooling due to pounding. The amount of rubber that extends beyond the normal piston stop is designed to compress and allow full cylinder stroke at 60 to 80 psi.

Bumpers should not be considered with the Viton Seal Option because of temperature or chemical limitations.

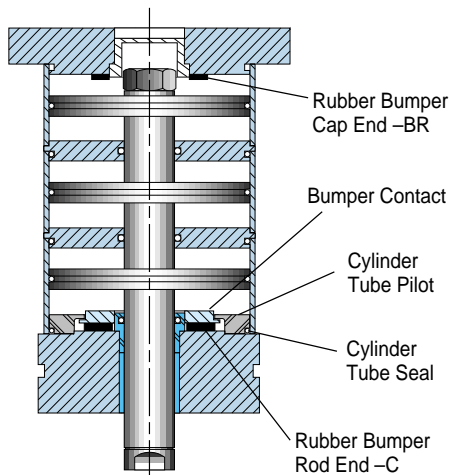

Application Tips– For applications such as punching, shearing, setting blind rivets, etc., where high forces are built up and then released very quickly, the proper method of **"Catching"** this load is to adjust the cylinder piston and the tooling so that at the point of breakthrough the piston is very close to the bumper. This reduces the dynamic load that the piston and bumper are required to absorb.

In such applications, however, it is highly recommended that either option -HS (shown on the next column) is used instead of rubber bumpers – or shock absorbers be considered and built into the tooling to assist in absorbing the force and dynamic loads generated.

1/2 NPT Ports

Retract Port Only Option -R12
 Extend Port Only Option -E12
 Both Ports Option -P12

Standard ports are enlarged to 1/2 NPT. This option is applied for the convenience of fitting selection and may result in faster cycling speeds.

Speed & Shock Control Using Hydraulics Option -HS

Std. Temperature Range (-25° to +250°F)

Also available with Viton Seals. Add Option -V
 Temperature Range (-15° to +400°F)

When Multi-Power® Presses are applied to applications such as punching, shearing, notching, etc., high inertia and impact forces are often encountered. To capture these potentially destructive forces, and prevent possible damage to tooling and cylinder, specify option -HS.

How it works– Fluid from an Air-Oil tank (see Application

Power Cylinder	MAXIMUM Operating psi
F19	150 psi
F38	150 psi
F55	150 psi
F72	110 psi
F93	90 psi

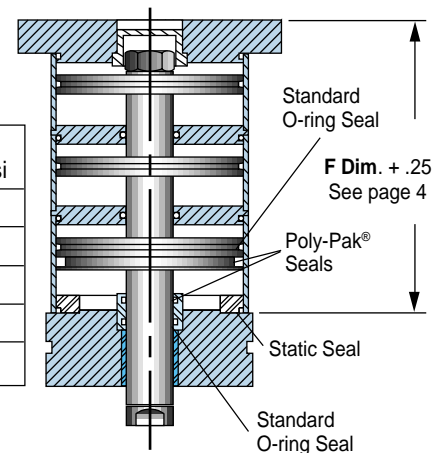

Tips under Air/Oil Tanks on page 9) is used for the return media. Fluid flow and cylinder speed are controlled by a needle or flow control valve. When the material shears and the cylinder tries to complete the stroke, the non-compressible fluid resists rapid movement. It "catches" the built up forces, dissipating them before the cylinder bottoms out. Thus the piston won't "pound" on the piston stop.

Beefed Up Construction– Seals on the piston, piston rod, and cylinder tube are increased in the single retract stage. The dynamic seals are Poly-Pak®. These combine an automatic lip type seal with an O-spring energizer for excellent sealing from zero to 500 psi. A thicker piston adds .25" to the "F" dimension.

Multi-Power[®] Air Presses

Provisions for operator protection are always the full responsibility of the user

Magnetic Piston for Position Sensing

Option -E

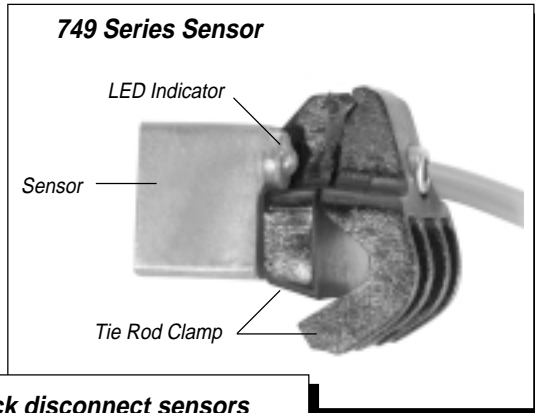

749 Series Sensors shown on a 4-stage Multi-Power[®] Cylinder (left)

- **Option -E** consists of a magnet bonded into the piston head. When the piston magnet moves past an external sensor, the magnetic field activates the sensor without physical contact.
- **Mounting**– The sensor includes an integral clamp that attaches rigidly to a tie rod and can be positioned anywhere along the length of the cylinder for very precise signaling.
- Multiple sensors can be mounted on any of the four tie rods.
- **Reliability**– The annular piston magnet is permanently bonded into a groove in the piston. It is a polarized permanent magnet of rubber bonded barium ferrite that is very stable and is not affected by shock. Under normal usage it will remain magnetized indefinitely.
- **Warning**– External magnetic fields and/or ferrous objects may affect the strength of the piston magnet therefore affecting sensor actuation and piston position indication. Labels noting this are affixed to the cylinder.
- **Please note there is an increase in base length of the cylinder to accommodate the magnet. The cap end stage only increases by 1".**

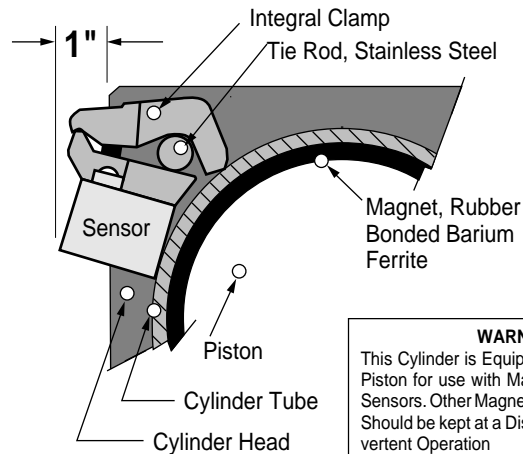

WARNING
This Cylinder is Equipped with a Magnetic Piston for use with Magnetically Operated Sensors. Other Magnetic Sensitive Devices Should be kept at a Distance to Avoid Inadvertent Operation

Sensor & Clamp Ordering Guide

Warning! Do not exceed sensor ratings. Permanent damage to sensor may occur. Power supply polarity **MUST** be observed for proper operation of sensors. See wiring diagrams included with each sensor.

Sensor Temperature Range: -30° to +80° C (-22° to +176° F)

LED Lighted Magnetic Piston Position Sensors			
Product Type	Prewired 9 ft. Part Number	Quick Disconnect Part Number	Electrical Characteristics
Reed Switch	749-000-004	749-000-504	5-240 VDC/VAC, 1 Amp Max., 30 Watt Max., SPST N.O., 3.0 Voltage Drop
Electronic	749-000-031	749-000-531	Sourcing, PNP, 6-24 VDC, 1.0 Amp Max., 0.5 Voltage Drop
Electronic	749-000-032	749-000-532	Sinking, NPN, 6-24 VDC, 1.0 Amp Max., 0.5 Voltage Drop

Female Cordsets for Quick Disconnect Sensors		
Length Part No.	2 Meter	5 Meter
	CFC-2M-12	CFC-5M-12

Option Specifications & Accessories

Provisions for operator protection are always the full responsibility of the user

Air/Oil Tanks

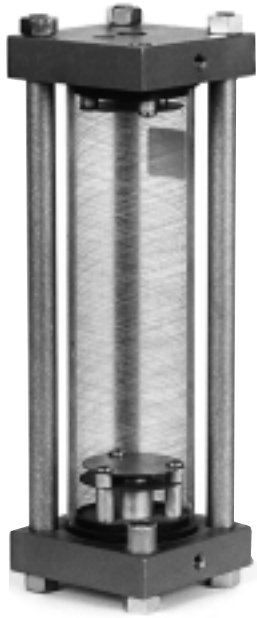

How they work

Air-Oil Tanks are used in conjunction with **Option -HS Hydraulic Shock Control**. These tanks provide a place to contain the fluid that is transferred to and from the power cylinder.

One Speed Circuit (below right)

Single tank models, used with a flow control valve, give speed control of the hydraulic fluid in one direction, and allow rapid flow in the opposite direction.

Thus, when used on an air press, the "ram-down" speed can be slowed to a desired rate leaving "ram-up" at full speed.

Use the convenient ordering guide at the right to select the appropriate 4" diameter Air/Oil Tank.

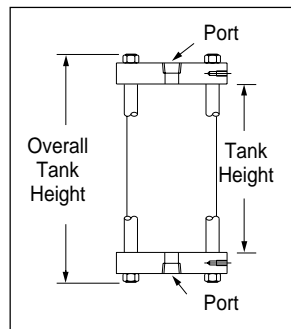

Air-Oil Tank Ordering Guide

Power Cylinder	Stroke Up to	Order Part Number	Overall Tank Height
F19	2	SAO-4 x 11	14.00
	4	SAO-4 x 14	17.00
	6	SAO-4 x 17	20.00
F38	2	SAO-4 x 11	14.00
	4	SAO-4 x 14	17.00
	6	SAO-4 x 17	20.00
F55	2	SAO-4 x 11	14.00
	4	SAO-4 x 14	17.00
	6	SAO-4 x 17	20.00
F72	2	SAO-4 x 11	14.00
	4	SAO-4 x 14	17.00
	6	SAO-4 x 17	20.00
F93	2	SAO-4 x 11	14.00
	4	SAO-4 x 14	17.00
	6	SAO-4 x 17	20.00

Please see Section 9 of Fabco-Air Catalog #CV9 for more air-oil tanks and complete specifications.

Application Tips

Two Speed & Shock Control

Single Air/Oil Tank with sequence, needle and shut-off valves give:

1. Rapid "Ram Down" stroke.
2. Automatic switch to controlled rate when resistance is met and pressure builds up.
3. Fluid catches cylinder when built-up forces are suddenly released (such as in punching applications), thus controlling the shock that could otherwise occur.

Always use 2-hand, anti tie-down systems for operator safety! Consult your local distributor for information and product availability.

Sequence Valve Model No's. RV-1 or RV-2 (see page 10)

4. Automatic return to rapid rate on "Ram Up" stroke.

This concept can be used with your Multi-Power® Air Press with **Option -HS**

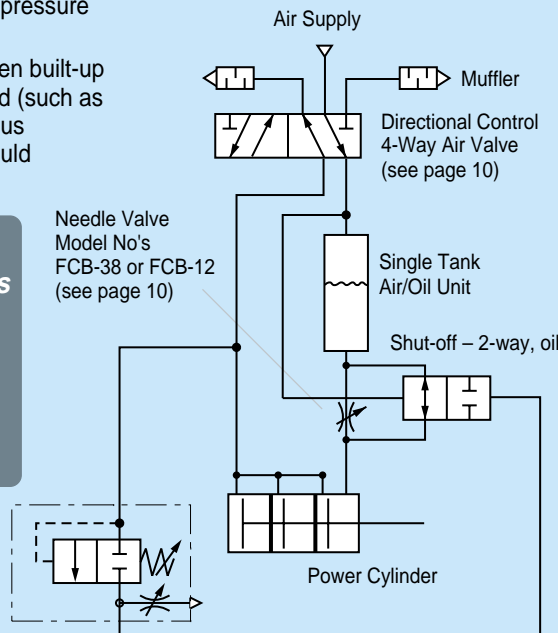

One Speed Circuit

A single Air/Oil Tank and flow control valve give hydraulic control with speed control on "Ram Down" with rapid "Ram Reverse."

Can be used with your Multi-Power® Air Press with **Option -HS**

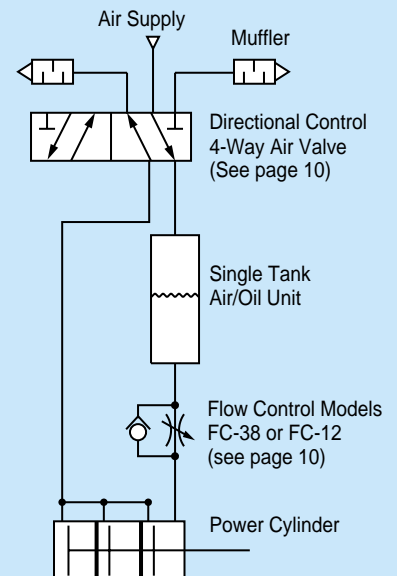

Multi-Power[®] Air Presses Valves

Provisions for operator protection are always the full responsibility of the user

Pressure Sensing/Sequence Valves



Cut-away view of RV-2 Sequence Valve

The "RV" Valve, with its unique poppet type seal, senses the pressure being applied and opens at your pre-adjusted set point to provide a pilot signal for circuit control. Because force is a direct function of pressure times area, the "RV" provides direct and precision adjustable force sensing.

If the application requires that a predetermined force be applied to an object at a point that may vary in physical dimensions (such as crimping, riveting, etc.) the "RV" is the control to use. It assures that the predetermined force (pressure) is applied regardless of variations in parts thickness. If the system pressure should drop below the "RV's" set point, the valve cannot open. The cycle will stop and wait for the required pressure rather than produce an unacceptable rivet or crimp. Once the required pressure is restored, the cycle will continue. (See pressure sensing circuit on page 3)

For 1/8 NPT Ports, order Model No. RV-1
For 1/4 NPT Ports, order Model No. RV-2

One Shot (Pulse) Valves



Cut-away view of OS-1

This 1/8 NPT ported valve provides a momentary output pulse at its cylinder port when pressure is applied to its inlet. No additional flow is possible until pressure at the inlet is removed, reset time is allowed, and pressure is reapplied.

For your air press, it can be used to convert a start signal from a hand or foot control to a pulse signal. This only allows one cycle of the press circuit even if the operator holds the starting device on. The operator must release the starting device to reset the one-shot/pulse valve— and then re-actuate to achieve the next cycle.

Order Model Number OS-1

Needle & Flow Control Valves



Needle Valve Flow Control

The unique design of the **Super-Vee™** control results in superior adjustability from full flow to bubble-tight shut-off with an orifice that provides precise repetition of selected flow rates.

Fine pitch threads raise and lower a straight stem needle with an angled "V" notch. The cross-sectional area of the "V" notch changes linearly as the stem moves through the control orifice— thus providing easier, less sensitive adjustability than is common to tapered needle type valves.

For Air or Hydraulic service to 150 psi.

Model Number Selection Guide

Port (NPT)	Flow Control	Needle Valve
1/8	FC-18	FCB-18
1/4	FC-14	FCB-14
3/8	FC-38	FCB-38
1/2	FC-12	FCB-12

Viton Seals are available for media compatibility. Specify **Option -V**

310 Series 3-Way Valves

This 10-32 ported control valve is available in push button, single air pilot, or double air piloted models. Valves can be used either normally closed or normally open. **Press side plates are drilled and tapped for easy valve mounting.**



Model 310-SB

Features:

- 10-32 ports • Brass body • Corrosion resistant construction • Operation to 150 psi
- Buna N seals (-30° to + 250°F)
- Free flow – 4.8 SCFM at 80 psi
- Not suitable for dry air applications

Model Number Selection Guide

Valve Operation	Model No.
Push button, spring return	310-SB
Single pilot, spring return	310-SP
Double pilot	310-DP

18 Series Directional Control Valves

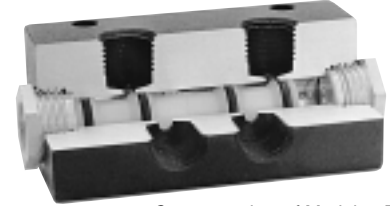

Cut-away view of Model 18DP-4

Features:

- 1/8 NPT ports • Rugged construction
- Parts anodized for corrosion resistance
- Generous air flow • Operation to 150 psi
- Buna N seals (-30° to + 250°F)
- Mounting holes match pre-tapped holes on the inside of press side plates

Model Number Selection Guide

Valve Operation	Model No.
3-Way, Single pilot, spring return	18SP-3
4-Way, Single pilot, spring return	18SP-4
3-Way, Double pilot	18DP-3
4-Way, Double pilot	18DP-4

See Fabco-Air Catalog #CV9 for your complete selection of air valves.

38 Series Directional Controls

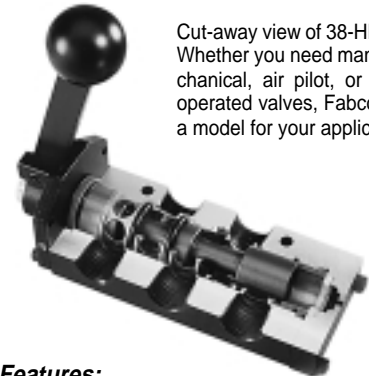

Cut-away view of 38-HL shown. Whether you need manual, mechanical, air pilot, or solenoid operated valves, Fabco-Air has a model for your application.

Features:

- 3/8 NPT ports • Rugged construction
- Parts anodized for corrosion resistance
- Generous air flow • Operation to 150 psi
- Buna N seals (-30° to + 250°F)
- Mounting holes to match pre-tapped holes on the inside of press side plates

Model Number Selection Guide

Valve Operation	Model No.
Hand lever, detented	38-HL
Hand lever, spring return	38-HLS
Single Pilot, spring return	38-SP
Double pilot	38-DP

Many other 38 Series Valves, including solenoid valve are also available. See Fabco-Air Catalog #CV9 for complete specifications.

Stand-alone Multi-Power® Cylinders

Need high force from an air cylinder? –Multi-Power® Cylinders may be your answer!

Original Multi-Power®
4-stage model shown with sensors

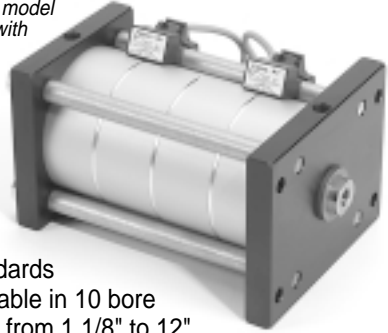

Standards
Available in 10 bore sizes from 1 1/8" to 12" and strokes to 12"

Pancake® – Multi-Power®
Cut-away view of 2-stage model

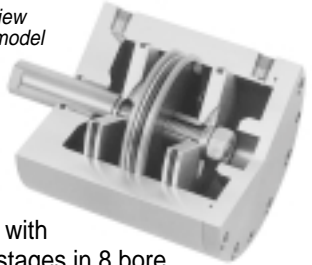

Available with 2, 3 or 4 stages in 8 bore sizes from 1/2" to 4" and strokes to 1-1/2"

Square 1® – Multi-Power®
Showing cut-away view of 2-stage model

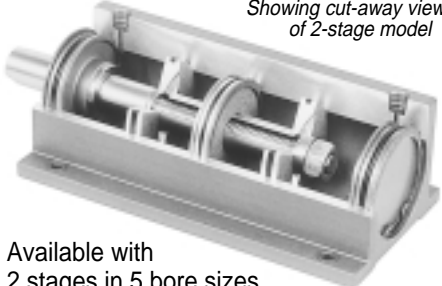

Available with 2 stages in 5 bore sizes from 3/4" to 2" and strokes to 2 1/2"

Longstroke™ – Multi-Power®
Showing cut-away view of 2-stage model

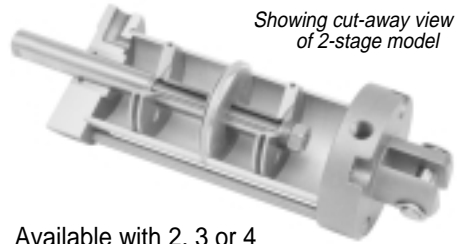

Available with 2, 3 or 4 stages in 4 bore sizes from 2" to 4" and strokes to 12"

The table below shows output forces attainable from various combinations of bore sizes and stages at 60 psi. For line pressures other than 60 psi use the following formula:

$$\text{Output force} = (\star \text{Effective Piston Area}) \times (\text{psi})$$

Once you've found the force you need, select an appropriate model from the Multi-Power® styles shown at the left. Please refer to Catalog CV-9 for complete details.

Bore Inches	Stages (Number of Pistons)	Total Effective Piston Area-Square Inches	★ Equivalent Bore of a Single Piston Cylinder	Force@ 60 psi	Single Stage Retract Piston Area, sq. in.
1/2	2	.35	.6	20	.15
	3	.50	.7	30	
	4	.65	.9	35	
3/4	2	.80	1.0	45	.36
	3	1.16	1.1	70	
	4	1.52	1.3	90	
1 1/8	2	1.8	1.5	108	.8
	3	2.6	1.8	156	
	4	3.4	2.1	204	
1 5/8	2	3.8	2.2	228	1.7
	3	5.6	2.6	336	
	4	7.3	3.0	438	
2	2	5.8	2.6	350	2.7
	3	8.5	3.2	512	
	4	11.2	3.7	674	
2 1/2	2	9.4	3.5	564	4.5
	3	13.8	4.2	828	
	4	18.3	4.8	1098	
3	2	13.7	4.1	822	6.6
	3	20.3	5.1	1218	
	4	26.9	5.8	1614	
4	2	24.4	5.6	1464	11.8
	3	36.1	6.8	2166	
	4	47.9	7.9	2874	
5	2	38.0	7.0	2280	18.4
	3	56.4	8.5	3384	
	4	74.8	9.7	4488	
6	2	55.3	8.4	3318	27.0
	3	82.3	10.2	4938	
	4	109.4	11.8	6564	
8	2	98.6	11.2	5916	48.5
	3	147.0	13.7	8820	
	4	195.4	15.8	11724	
10	2	153.9	14.0	9234	75.3
	3	229.3	17.1	13758	
	4	304.7	19.7	18282	
12	2	222.9	16.8	13374	109.9
	3	332.8	20.6	19968	
	4	442.7	23.7	26562	