

Particulate Filter

F43

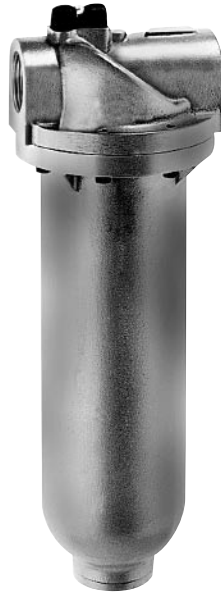
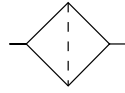

F43-0E-000

Features

- Heavy-duty Cast Aluminum Housings to Withstand Operating Pressures Up to 300 PSIG*
- Differential Pressure Indicator to Eliminate the Guesswork of Element Replacement
- Unique Drain Mounting Plate Design Offers a Trouble-free Method for Interchanging and Installing External Drains
- 5 Micron High Flow Particulate Element

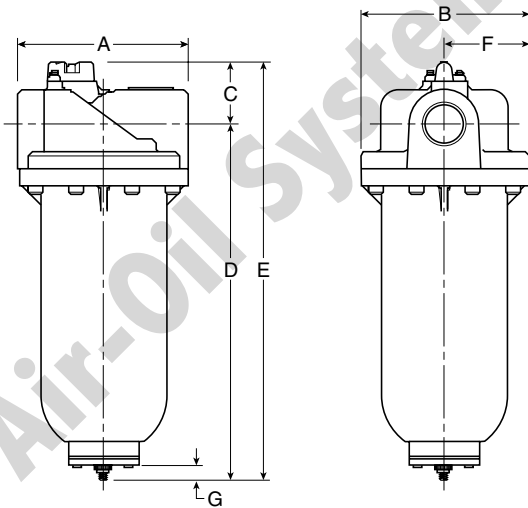

Dimensions

Models	Inches (mm)	A	B	C	D	E	F	G
Standard Unit F43-0E-000		8.94 (227)	8.88 (225.5)	3.48 (88)	25.96 (659.4)	29.44 (748)	4.44 (112.8)	.55 (14)

= "Most Popular"

Specifications

Flow Capacity*	3	2900 SCFM (1368 dm ³ /s)
Maximum Supply Pressure	without DP2 with DP2	300 PSIG (20.7 bar)** 150 PSIG (10.3 bar)
Operating Temperature	32° to 150°F (0° to 65.5°C)	
Port Size	NPT / BSPP-G	3
Standard Filtration	Micron	5
Useful Retention†	oz. (cm ³)	14 (418.7)
Weight	lb. (kg)	32.8 (14.9)

* Inlet pressure 150 PSIG (10.3 bar). Pressure drop of 5 PSID (0.3 bar).

** Without pressure indicator – Max. supply pressure is 300 PSIG (20.7 bar).

† Useful retention refers to volume below the quiet zone baffle.

"F" Series Filters, Type "A" 5 micron elements: All Wilkerson Type "A" 5 micron elements **meet or exceed ISO Class 3** for maximum particle size and concentration of solid contaminants.

Materials of Construction

Baffle	Plated Steel
Body	Aluminum
Bowls	Aluminum
Deflector	Plated Steel
Filter Element	Polyethylene
Seals	Fluorocarbon
Stud	Plated Steel

NOTE: Standard filter includes tapped 1/2 NPT / BSPP-G drain plate.
To order internal float drain shown, order drain adapter plate GRP-95-391 and automatic drain GRP-95-981.

= "Most Popular"

Replacement Element Kit

Element, F43, 5 Micron, Fluorocarbon O-rings.....FRP-95-508

Accessories

- Cap, Differential Pressure Indicator –
For pressures over 150 PSIG..... GRP-95-022
- Drain, Automatic, Internal, Fluorocarbon,
1/8 NPT GRP-95-981
- Drain Plate Kit (.56 Dia.) –
For use with internal auto float drain..... GRP-95-391
- Drain Plate Kit –
1/4 NPT tapped drain port..... GRP-95-392
1/2 NPT tapped drain port GRP-95-393
- Gauge, Differential Pressure DP3-01-000
- Indicator, Differential Pressure DP2-01-001
- Manual Override for Auto Float Drain –
GRP-95-981 required GRP-96-000

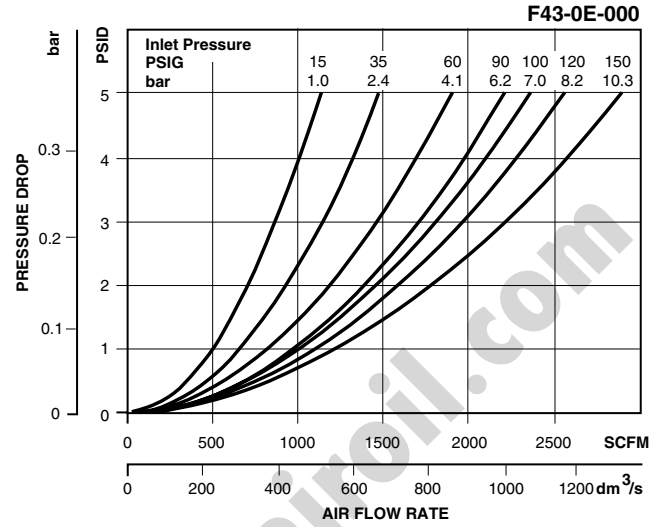

Ordering Information

Model Type	Port Size	Metal Bowl
F43	3	F43-0E-000 (Includes 1/2 NPT / BSPP-G Drain Plate)

Options - To order an option supplied with the unit model, add the appropriate coded suffix letter in the designated position of the model number.

