



# Emergency Stop Switches Operating Instructions



**Type ES-P (Plastic)**  
Knock-out for plastic version



**Type ES-SS (Stainless Steel)**  
Mirror Polished Finish



**Type ES-SS(P) (Stainless Steel)**  
With button protection shroud with padlock holes for lock off during maintenance



**Type ESL-SS (Stainless Steel)**



**Type ESL-SS(P) (Stainless Steel)**  
With button protection shroud with padlock holes for lock off during maintenance



**Type ESL-SS(L) (Stainless Steel)**  
With 2-colour LED



**Type ESL-SS(LP) (Stainless Steel)**  
With 2-colour LED and button protection shroud with padlock holes for lock off during maintenance

## IMPORTANT NOTE:

Read and understand these instructions before installing, operating, or maintaining this equipment.

The product is designed to be a component of a customised safety orientated control system. It is the responsibility of the user to ensure the correct overall functionality of its systems and machines. IDEM, its subsidiaries and affiliates, are not in a position to guarantee all of the characteristics of a given system or product not designed by IDEM.

## Application:

Emergency Stop Switches are mounted on machines and sections of plant conveyors that cannot be protected by guards.

In combination with any dual channel safety monitoring controllers these switches can be used as emergency stop devices and monitored for up to Category 4/PLe to ISO13849-1.

## Operation:

All Emergency Stop Switches conform to European Standard EN ISO 13850 and IEC 60947-5-5. They have a positive mechanical linkage between the switch contacts and the E-Stop Button. The switches are mechanically latched and can then only be returned to the operational condition by a pressing the reset button as required by EN ISO 13850 and IEC 60947-5-5.

## Installation Guide:

1. Installation of all switches must be in accordance with a risk assessment for the individual application and in accordance with local wiring regulations and EN60204-1. Installation must only be carried out by competent personnel and in accordance with these instructions.
2. M4 mounting bolts must be used to fix the switches. Tightening torque for mounting bolts to ensure reliable fixing is 4 Nm. Tightening torque for the lid screws, conduit entry plugs and cable glands must be 1.5 Nm to ensure IP seal. Only use the correct size gland for the conduit entry and cable outside diameter.
3. Check operation of all switches and the control circuits by activating the switch (depress the Red Button) and resetting each switch by twisting the Red Button. Ensure each time that the switches latch off and require manual resetting.
4. For versions with the Protection Shroud ensure that the padlock size is suitable to prevent re-setting of the button.

## Maintenance:

- Every Month: Check correct operation of the control circuits and latching mechanism. Inspect for damage to the E Stop button or casing. Replace any switch displaying damage.
- Every 6 Months: Isolate power and remove cover. Check screw terminal tightness and check for signs of moisture ingress. Never attempt to repair any switch.

## LED Wiring examples (if fitted):

Black (or Terminal 2) is 0V (or Neutral for 110V and 230V ac versions).  
When power is applied to the Red wire (or Terminal 1), the LED will illuminate Red.  
When power is applied to the Green wire (or Terminal 3), the LED will illuminate Green.

## LED has 2 colours

### Recommended Colour Usage:

LED Red- Stopped  
LED Green - Run



## Wiring circuits for Explosion Proof Versions:

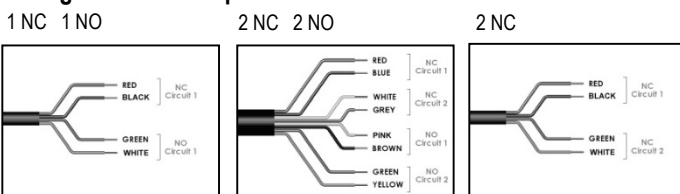

<b>Standards:</b>	IEC 60947-5-5 UL508 EN ISO 13850
Case Material	Stainless Steel 316 or Plastic
Safety Contact type	IEC 60947-5-1 Double break Type Zb
Contact Material	Silver
Termination	Clamp up to 2.5 sq. mm conductors
Rating	Utilisation Category : AC15
Operational Rating	AC15 A300 240V. 3A /120V 6A. ac
Thermal Current (Ith)	10A.
Rated Insulation Voltage (Ui)	500V.
Withstand Voltage (Uimp)	2500V.
Short Circuit Overload Protection	Fuse Externally 10A. (FF)
Operating Temperature	-25C / 80C.
Enclosure Protection	IP67 Plastic or IP69K Stainless Steel (NEMA 6)

## Optional Explosion Proof Contact Block:

<b>Type</b>	IDEM LS-EX internal switch
<b>Classification</b>	Ex d IIC T6 (-20C Ta 60C) Gb Ex tb IIIC T85C (-20C Ta 60C) Db
<b>Rated Voltage</b>	250V ac/dc
<b>Rated Current</b>	2 pole 4A. 4 pole 2.5A.

## Safety Classification and Reliability Data:

<b>Mechanical Reliability B10d</b>	1.5 x 10 <sup>6</sup> operations at 100mA load
<b>ISO 13849-1</b>	up to PLe depending upon system architecture
<b>EN 62061</b>	up to SIL3 depending upon system architecture
<b>Safety Data - Annual Usage</b>	8 cycles per hour / 24 hours per day / 365 days
	MTTFd 214 years

## IMPORTANT-

**SPECIFIC CONDITIONS OF USE FOR EX VERSIONS:**  
THE INTEGRAL CABLE SHALL BE SUITABLY PROTECTED FROM PHYSICAL DAMAGE AND ABRASION.  
THE INTEGRAL CABLE IS TO BE TERMINATED IN A SUITABLE TERMINAL FACILITY.

DIMENSIONS: ES-P

# Emergency Stop Switches

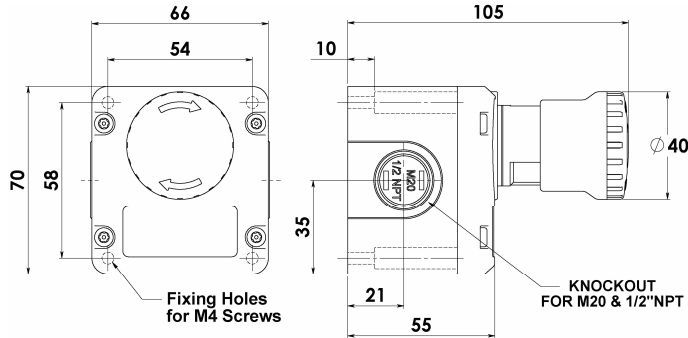

DIMENSIONS: ES-SS  
ES-SS(P)

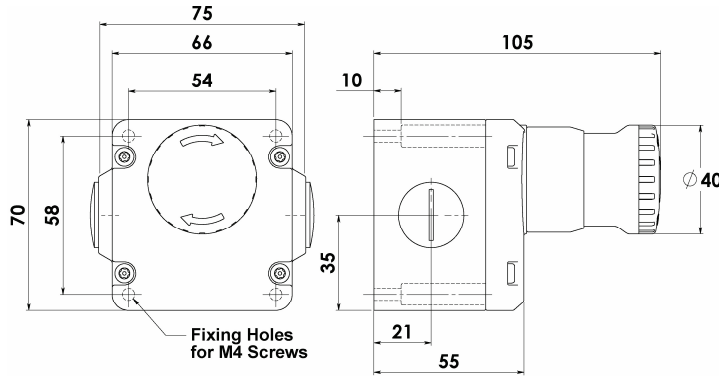

DIMENSIONS: ESL-SS  
ESL-SS(P)  
ESL-SS(L)  
ESL-SS(LP)

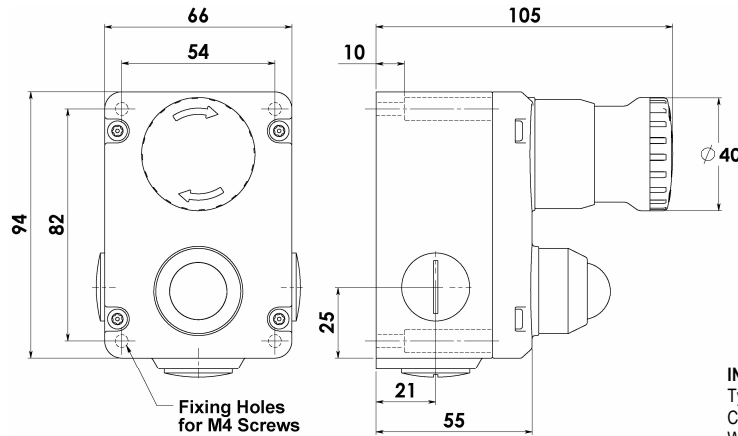

**INFORMATION WITH REGARD TO UL508:**

Type 1 Enclosure  
Contact Blocks A300 230V/3A 120V/6A  
Wire range: 16AWG – 12AWG Stranded Copper Conductors  
Terminal Torque 7lb/in (0.8Nm)  
24V LED (if fitted) powered by LVLC or Class 2 only.



**SPECIAL NOTE:**  
Where required by local regulations please affix the supplied yellow "EMERGENCY STOP" sticker as shown in the image.



**SPECIAL NOTE:**  
Where the Risk Assessment identifies that inadvertent operation of the E-Stop button may occur during use or breakage and loss of the button function is foreseen, it may be preferable to specify the protection shroud version. If the Risk Assessment for the particular application allows use of the protection shroud, it is recommended consideration be given to the conditions of operation of the button during spontaneous operation as the shroud is not suitable for traditional E-Stop palm actuation of the button. The Risk Assessment must clearly identify any restrictions to the proper use of the button including any training or the requirement to place any restriction notices at the E-Stop location (e.g. "FINGER OPERATION REQUIRED").



**WARNING: DO NOT DEFEAT, TAMPER, OR BYPASS THE SAFETY FUNCTION. FAILURE TO DO SO CAN RESULT IN DEATH OR SERIOUS INJURY.**

**AVERTISSEMENT: NE PAS DESACTIVER, MODIFIER, RETIRER, OU CONTOURNER CETI INTERVERROUILLAGE IL PEUT EN RESULTER DES BLESSURES GRAVES DU PERSONNEL UTILISATEUR.**

**Original Instructions.**

To request this data sheet in other languages please contact [info@idemsafety.com](mailto:info@idemsafety.com)  
Um dieses Datenblatt in Deutscher Sprache wenden Sie sich bitte anfordern [info@idemsafety.com](mailto:info@idemsafety.com)  
Pour obtenir cette fiche en Français, veuillez contacter [info@idemsafety.com](mailto:info@idemsafety.com)  
Para solicitar esta hoja de datos en Español, por favor contacto con [info@idemsafety.com](mailto:info@idemsafety.com)