

EXTREME FORCE, HYDRAULIC CLASS ELECTRIC ACTUATORS

RSX

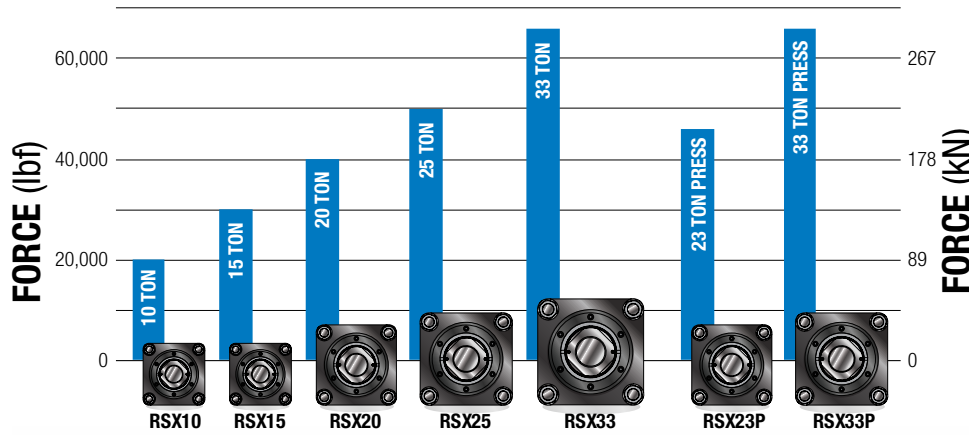

RSX actuators are an ideal choice for replacing hydraulic cylinders. These high force electric actuators with planetary roller screws are available for forces up to 66,000 lbf (294 kN). Designed for 100% duty cycle, rugged service and long life.

THRUST TUBE

- Steel thrust tube supports extremely high force capabilities
- Salt bath nitride treatment provides excellent corrosion resistance, surface hardness and is very resistant to adherence of potential contaminants

FIELD REPLACEABLE CARTRIDGE

One piece assembly designed for easy field replacement

PLANETARY ROLLER SCREWS

- Precision ground planetary roller screws
- High force with high dynamic load rating for long life
- High screw accuracy $\pm 0.0102\text{mm}/300\text{mm}$ ($\pm 0.0004"/\text{ft.}$)

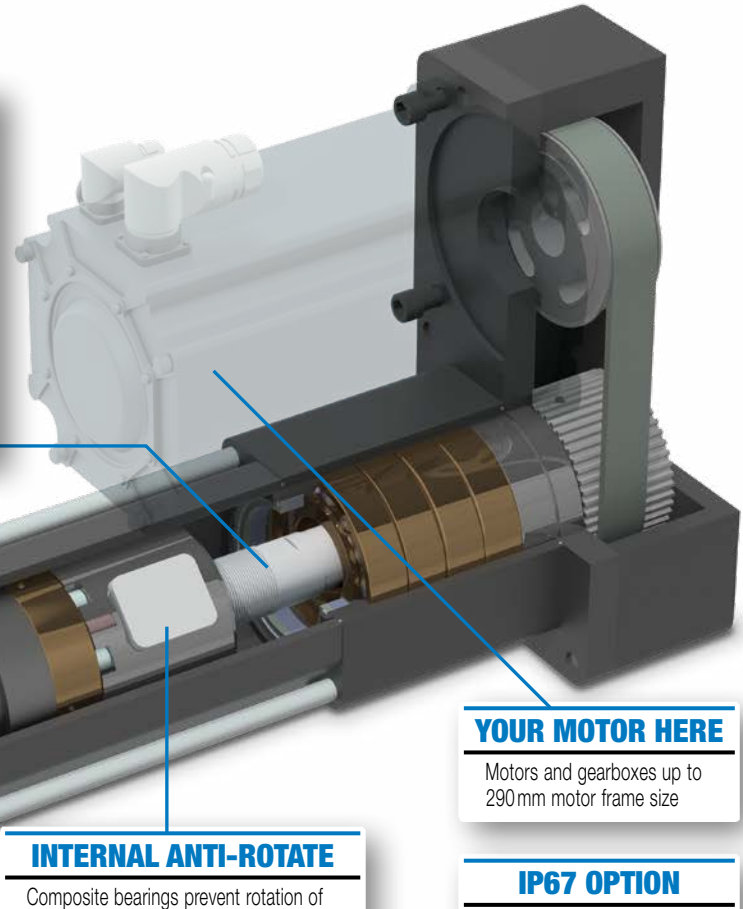

YOUR MOTOR HERE

Motors and gearboxes up to 290mm motor frame size

INTERNAL ANTI-ROTATE

Composite bearings prevent rotation of the thrust tube

IP67 OPTION

Resists water ingress 1m deep for up to 30 minutes (static)

HEAVY DUTY CONSTRUCTION

All external component are Type III hard-coat anodized aluminum or zinc plated steel for rugged use and corrosion resistance

Available Options:

Mounting

Mounting Plates; Front Flange; Trunnion Mount; Extended Tie Rods

Rod Ends

English Threads; Rod Clevis

Limit Switches

With tie-rod mounting bracket

White Paint & Stainless Steel

For food grade applications

Oil Cooled

For extended high duty cycle/high force performance

HIGH FORCE, HYDRAULIC CLASS ELECTRIC ACTUATORS **RSX**

Specifications

RSX SIZE (TONNAGE RATING)	MAX. STROKE	SCREW CODE	SCREW LEAD	LEAD ACCURACY	BACKLASH	MAX. FORCE	MAX. SPEED	DYNAMIC LOAD RATING
	in		turns/in	in/ft	in	lbf	in/sec	lbf
10	59	BN01	1	0.004	0.015	20,000	25	22,500
10	59	BN02	2	0.004	0.015	20,000	11	37,420
10	50	RN12	2.12	0.0004	0.0012	20,000	30	58,921
15	59	BN01	1	0.004	0.015	30,000	25	22,500
15	59	BN02	2	0.004	0.015	30,000	11	37,420
15	50	RN12	2.12	0.0004	0.0012	30,000	30	60,541
20	50	RN12	2.12	0.0004	0.0012	40,000	30	60,541
25	48	RN10	2.54	0.0004	0.0012	50,000	20	99,519
33*	48	RN10	2.54	0.0004	0.0012	66,000	20	99,519
23P*	28	RN12	2.12	0.0004	0.0012	46,000**	30	60,541
33P*	39	RN10	2.54	0.0004	0.0012	66,000**	20	99,519
	mm		mm/rev	mm/300mm	mm	kN	mm/sec	kN
10	1500	BN01	25.4	0.1	0.38	89	640	100
10	1500	BN02	12.7	0.1	0.38	89	280	166
10	1270	RN12	12	0.01	0.03	89	760	262
15	1500	BN01	25.4	0.1	0.38	133	640	100
15	1500	BN02	12.7	0.1	0.38	133	280	166
15	1270	RN12	12	0.01	0.03	133	760	269
20	1270	RN12	12	0.01	0.03	178	760	269
25	1220	RN10	10	0.01	0.03	222	510	443
33*	1220	RN10	10	0.01	0.03	294	510	443
23P*	710	RN12	12	0.01	0.03	205**	760	269
33P*	990	RN10	10	0.01	0.03	294**	510	443

*Call Tolomatic for availability

**Max. force only in extend

Dimensions

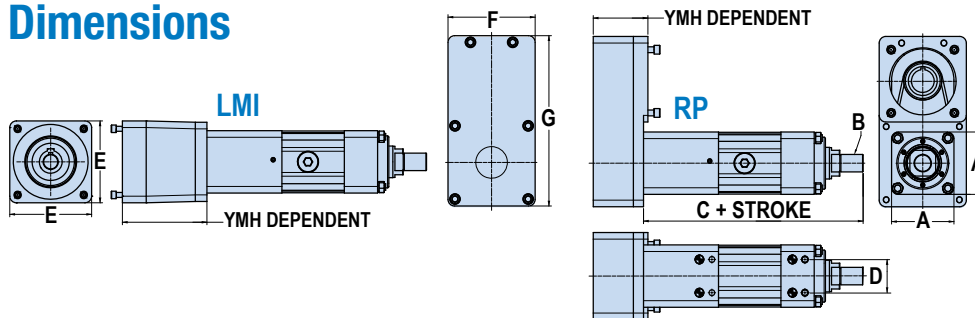

RSX33 Dimensions available upon request

	A	B	C (RN)	C (BN01)	C (BN02)	D	E	F	G
10 & 15	5.9	1 7/8-12 UN-2A	23.1	25.2	27.3	3.1	7.8	8.3	16.8
20 & 23P	7.5	2 1/2-12 UN-2A	24.6	-	-	3.1	7.8	8.3	16.8
25 & 33P	8.7	2 1/2-8 UN-2A	31.7	-	-	4.5	11.3	11.3	23.0

Dimensions in inches (in)

	A	B	C (RN)	C (BN01)	C (BN02)	D	E	F	G
10 & 15	150	M42 x 4.5-6g	588	641	693	80	197	210	426
20 & 23P	190	M64 x 3.0-6g	624	-	-	80	197	210	426
25 & 33P	220	M64 x 3.0-6g	804	-	-	115	288	286	584

Dimensions in millimeters (mm)



MADE IN U.S.A.

TolomaticTM
EXCELLENCE IN MOTION

COMPANY WITH
QUALITY SYSTEM
CERTIFIED BY DNV
= ISO 9001 =
Certified site: Hamel, MN

USA - Headquarters

Tolomatic Inc.
3800 County Road 116
Hamel, MN 55340, USA
Phone: (763) 478-8000
Toll-Free: **1-800-328-2174**
sales@tolomatic.com
www.tolomatic.com

MEXICO

Centro de Servicio
Parque Tecnológico Innovación
Int. 23, Lateral Estatal 431,
Santiago de Querétaro,
El Marqués, México, C.P. 76246
Phone: +1 (763) 478-8000
help@tolomatic.com

EUROPE

Tolomatic Europe GmbH
Elisabethenstr. 20
65428 Rüsselsheim
Germany
Phone: +49 6142 17604-0
help@tolomatic.eu
www.tolomatic.com/de-de

CHINA

**Tolomatic Automation Products
(Suzhou) Co. Ltd.**
No. 60 Chuangye Street, Building 2
Huqiu District, SND Suzhou
Jiangsu 215011 - P.R. China
Phone: +86 (512) 6750-8506
Tolomatic_China@tolomatic.com

All brand and product names are trademarks or registered trademarks of their respective owners. Information in this document is believed accurate at time of printing. However, Tolomatic assumes no responsibility for its use or for any errors

that may appear in this document. Tolomatic reserves the right to change the design or operation of the equipment described herein and any associated motion products without notice. Information in this document is subject to change without notice.

Visit www.tolomatic.com for the most up-to-date technical information