

Series XV03

Series XV03

The AVENTICS XV03 series provides a reliable basis for both compact handling systems and complex automation solutions. The XV-Compact variant features a wide range of valve functions and accessories as well as the relevant electrical connectivity for general requirements in factory automation and other industries. With the simple support of D-Sub and terminal strips through to IO-Link and several XVES series fieldbus protocols, all requirements for decentralized control are also met. The unique online configurator makes it easy to define the optimum configuration for the base plate and the entire valve system, including accessories.

- Easy and flexible custom specific configurations via online configurator
- Low energy consumption
- Various connection options possible



product overview

	Page
2x3/2-directional valve	
2x3/2-directional valve, Series XV03, NO/NO, Manual override: without detent.....	4
2x3/2-directional valve, Series XV03, NO/NO, Manual override: with detent.....	5
2x3/2-directional valve, Series XV03, NC/NC, Manual override: without detent.....	6
2x3/2-directional valve, Series XV03, NC/NC, Manual override: with detent.....	7
2x3/2-directional valve, Series XV03, NC/NO, Manual override: without detent.....	8
2x3/2-directional valve, Series XV03, NC/NO, Manual override: with detent.....	9
5/2-directional valve	
5/2-directional valve, Series XV03, with spring return, manual override: without detent.....	10
5/2-directional valve, Series XV03, with spring return, Manual override: with detent.....	11
5/2-directional valve, Series XV03, with air spring return, manual override: without detent.....	12
5/2-directional valve, Series XV03, with air spring return, Manual override: with detent.....	13
5/2-directional valve, Series XV03, double solenoid, manual override: without detent.....	14
5/2-directional valve, Series XV03, double solenoid, Manual override: with detent.....	15
5/3-directional valve	
5/3-directional valve, Series XV03, pressurized enter, manual override: without detent.....	16
5/3-directional valve, Series XV03, pressurized center, Manual override: with detent.....	17
5/3-directional valve, Series XV03, exhausted center, manual override: without detent.....	18
5/3-directional valve, Series XV03, Exhausted Center, Manual override: with detent.....	19
5/3-directional valve, Series XV03, closed center, manual override: without detent.....	20
5/3-directional valve, Series XV03, closed center, Manual override: with detent.....	21
Accessories overview electrical connection technologies	
Accessories XV03	
Bus coupler, series XVES Profinet.....	22
Bus coupler, series XVES EtherCAT.....	24
Bus coupler, series XVES EtherNet/IP.....	26
Bus coupler, series XVES Modbus TCP.....	28
Bus coupler, series XVES Profibus DP.....	30
Bus coupler, series XVES IO-Link.....	32
Multipole connection, 25-pin, on top.....	34
Multipole connection, 44-pin, on top.....	35
Multipole connection, 25-pin, on the side.....	36
Multipole connection, 44-pin, on the side.....	37
Multipole connection, terminal 27, on top.....	38
Supply plate, series XV03.....	39
Blank plate, series XV03.....	40
Air supply sandwich plate, series XV03.....	41
Exhaust sandwich plate, series XV03.....	42

2x3/2-directional valve, Series XV03, NO/NO, Manual override: without detent

Flow: 330 l/min
 Activation: Electrically operated
 Actuating control: Double Solenoid
 Switching principle: 2x 3/2 NO/NO, with spring return

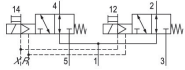

Switching principle	Operational voltage	Pilot	Power consumption DC [W]	Min. working pressure [bar]	Min. working pressure [bar]	Min. control pressure [bar]	Max. control pressure [bar]	Part No.
2x 3/2 NO/NO, with spring return	24 V DC	External	0.55	-0.95	8	3	8	R572A2BA0MA00F1

Dimensions

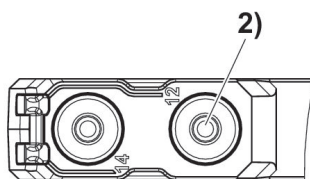
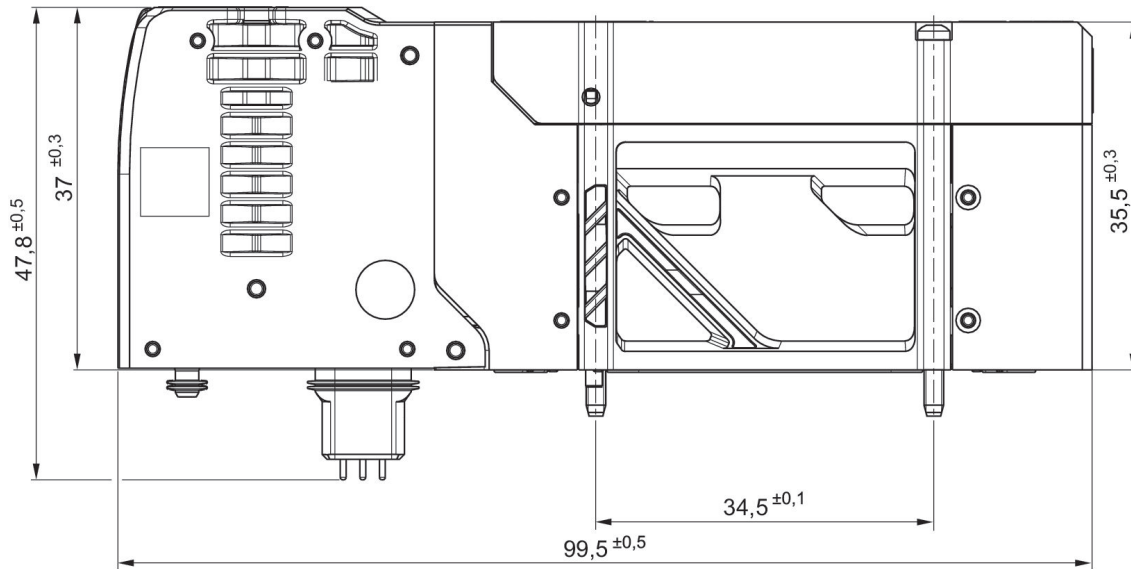

- 1) with detent
- 2) without detent
- 3) Ports: M7

2x3/2-directional valve, Series XV03, NO/NO, Manual override: with detent

Flow: 330 l/min
 Activation: Electrically operated
 Actuating control: Double Solenoid
 Switching principle: 2x 3/2 NO/NO, with spring return

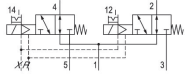

Switching principle	Operational voltage	Pilot	Power consumption DC [W]	Min. working pressure [bar]	Min. working pressure [bar]	Min. control pressure [bar]	Max. control pressure [bar]	Part No.
2x 3/2 NO/NO, with spring return	24 V DC	External	0.55	-0.95	8	3	8	R572A2CA0MA00F1

Dimensions

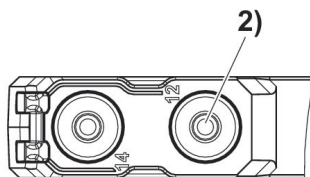
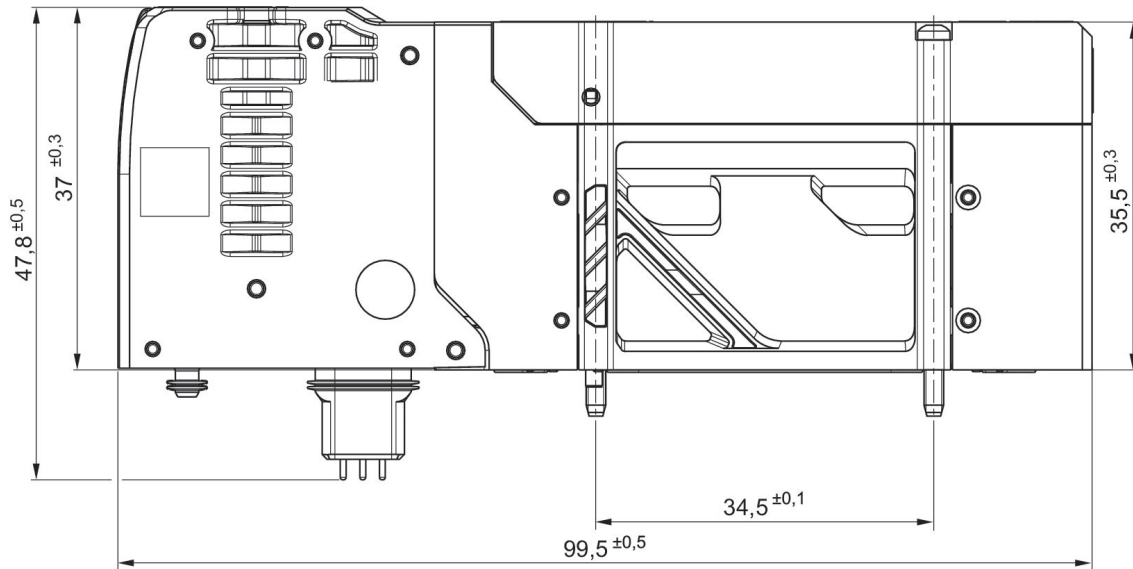

- 1) with detent
- 2) without detent
- 3) Ports: M7

2x3/2-directional valve, Series XV03, NC/NC, Manual override: without detent

Flow: 330 l/min
 Activation: Electrically operated
 Actuating control: Double Solenoid
 Switching principle: 2x 3/2 NC/NC, with spring return

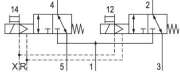

Switching principle	Operational voltage	Pilot	Power consumption DC [W]	Min. working pressure [bar]	Min. working pressure [bar]	Min. control pressure [bar]	Max. control pressure [bar]	Part No.
2x 3/2 NC/NC, with spring return	24 V DC	External	0.55	-0.95	8	3	8	R572A2B-D0MA00F1

Dimensions

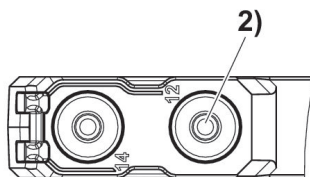
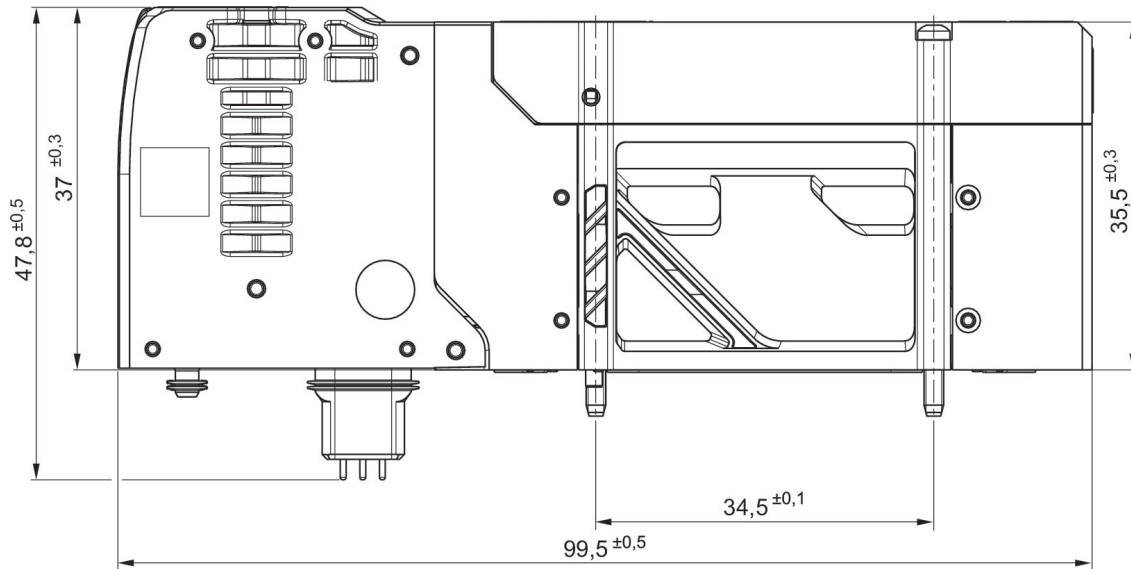

- 1) with detent
- 2) without detent
- 3) Ports: M7

2x3/2-directional valve, Series XV03, NC/NC, Manual override: with detent

Flow: 330 l/min
 Activation: Electrically operated
 Actuating control: Double Solenoid
 Switching principle: 2x 3/2 NC/NC, with spring return

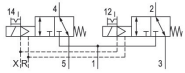

Switching principle	Operational voltage	Pilot	Power consumption DC [W]	Min. working pressure [bar]	Min. working pressure [bar]	Min. control pressure [bar]	Max. control pressure [bar]	Part No.
2x 3/2 NC/NC, with spring return	24 V DC	External	0.55	-0.95	8	3	8	R572A2CD0MA00F1

Dimensions

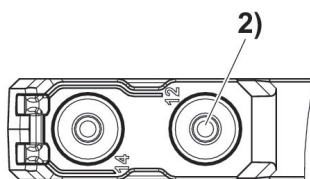
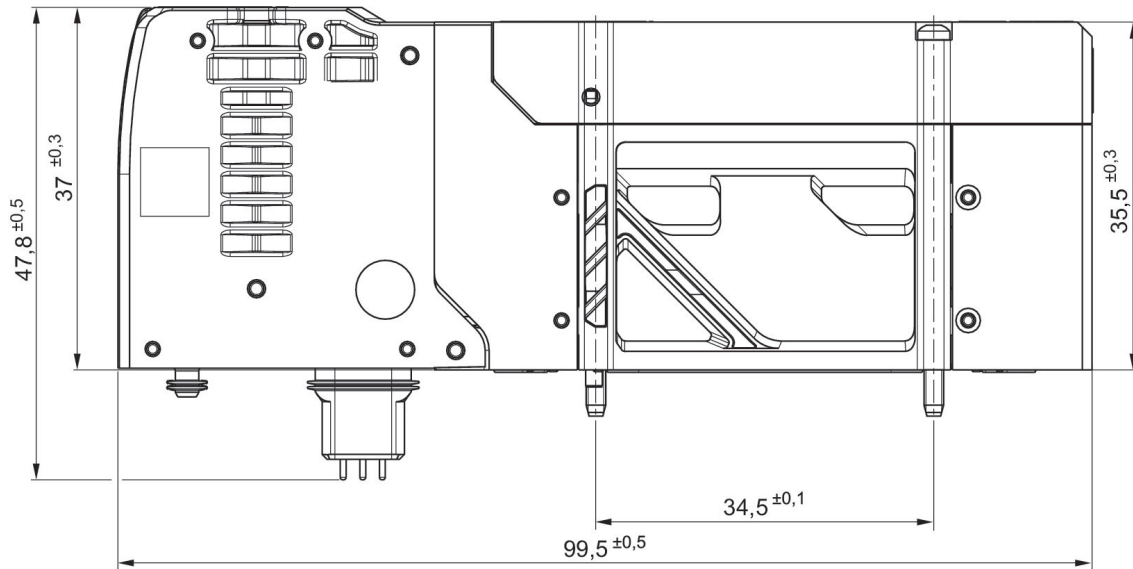

- 1) with detent
- 2) without detent
- 3) Ports: M7

2x3/2-directional valve, Series XV03, NC/NO, Manual override: without detent

Flow: 330 l/min
 Activation: Electrically operated
 Actuating control: Double Solenoid
 Switching principle: 2x 3/2 NC/NO, with spring return

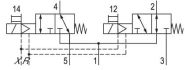

Switching principle	Operational voltage	Pilot	Power consumption DC [W]	Min. working pressure [bar]	Min. working pressure [bar]	Min. control pressure [bar]	Max. control pressure [bar]	Part No.
2x 3/2 NC/NO, with spring return	24 V DC	External	0.55	-0.95	8	3	8	R572A2BF0MA00F1

Dimensions

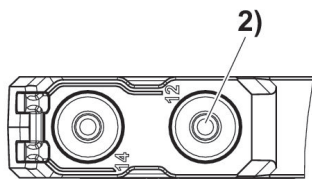
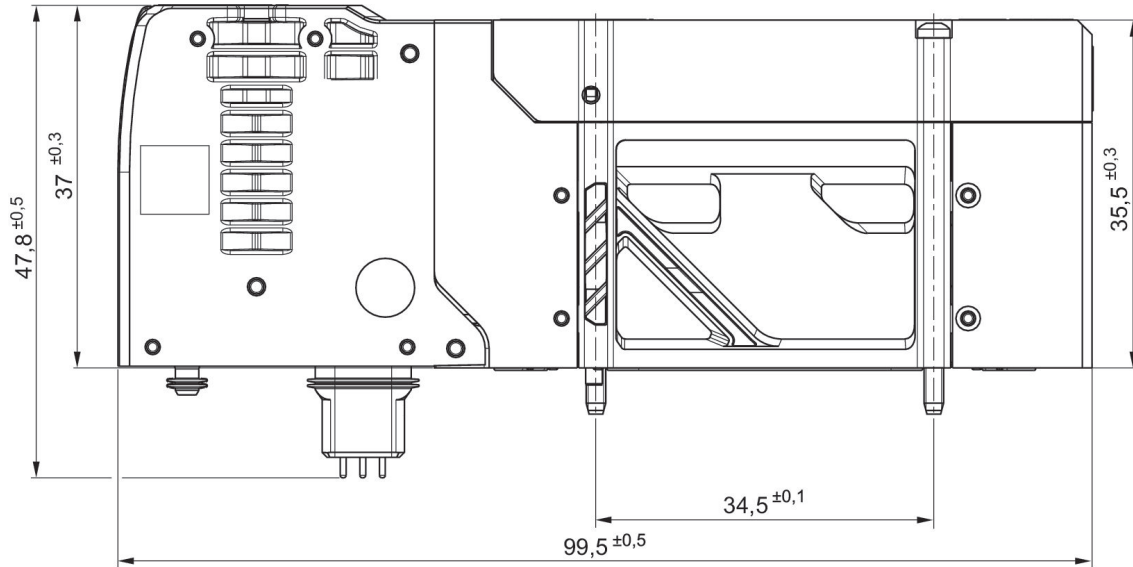

- 1) with detent
- 2) without detent
- 3) Ports: M7

2x3/2-directional valve, Series XV03, NC/NO, Manual override: with detent

Flow: 330 l/min
 Activation: Electrically operated
 Actuating control: Double Solenoid
 Switching principle: 2x 3/2 NC/NO, with spring return

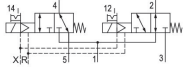

Switching principle	Operational voltage	Pilot	Power consumption DC [W]	Min. working pressure [bar]	Min. working pressure [bar]	Min. control pressure [bar]	Max. control pressure [bar]	Part No.
2x 3/2 NC/NO, with spring return	24 V DC	External	0.55	-0.95	8	3	8	R572A2CF0MA00F1

Dimensions

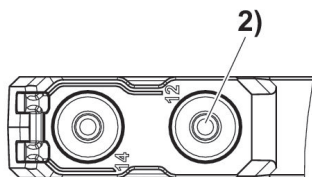
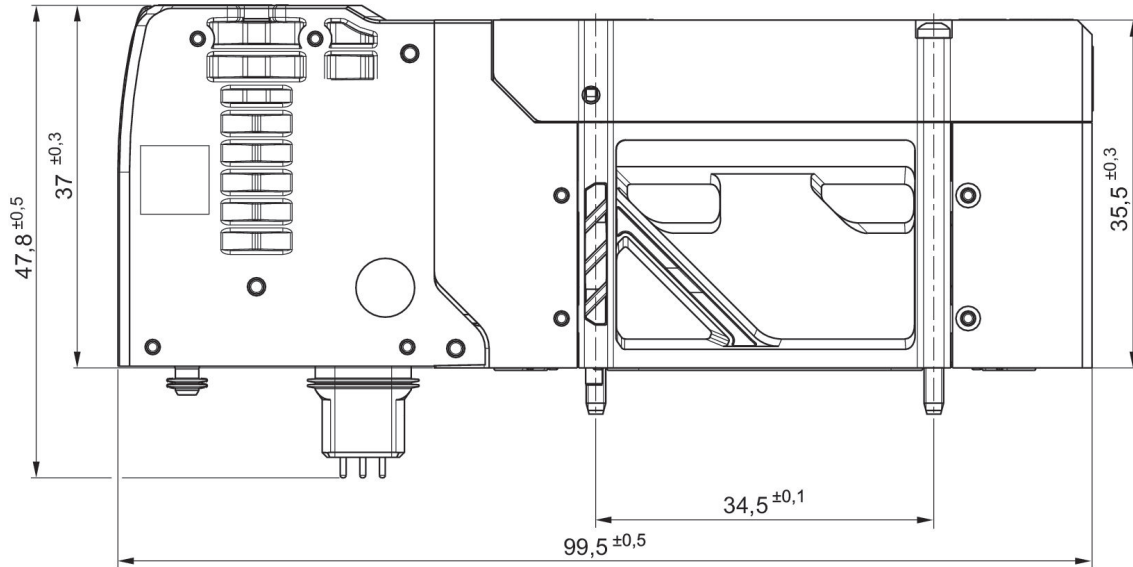

- 1) with detent
- 2) without detent
- 3) Ports: M7

5/2-directional valve, Series XV03, with spring return, manual override: without detent

Flow: 345 l/min
 Activation: Electrically operated
 Actuating control: Single Solenoid
 Switching principle: 5/2, with spring return

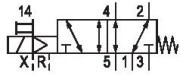

Switching principle	Operational voltage	Pilot	Power consumption DC [W]	Min. working pressure [bar]	Min. working pressure [bar]	Min. control pressure [bar]	Max. control pressure [bar]	Part No.
5/2, with spring return	24 V DC	External	0.55	-0.95	8	3	8	R572A2B10MA00F1

Dimensions

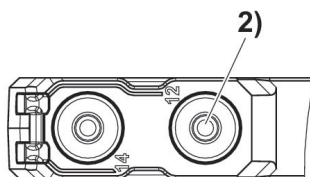
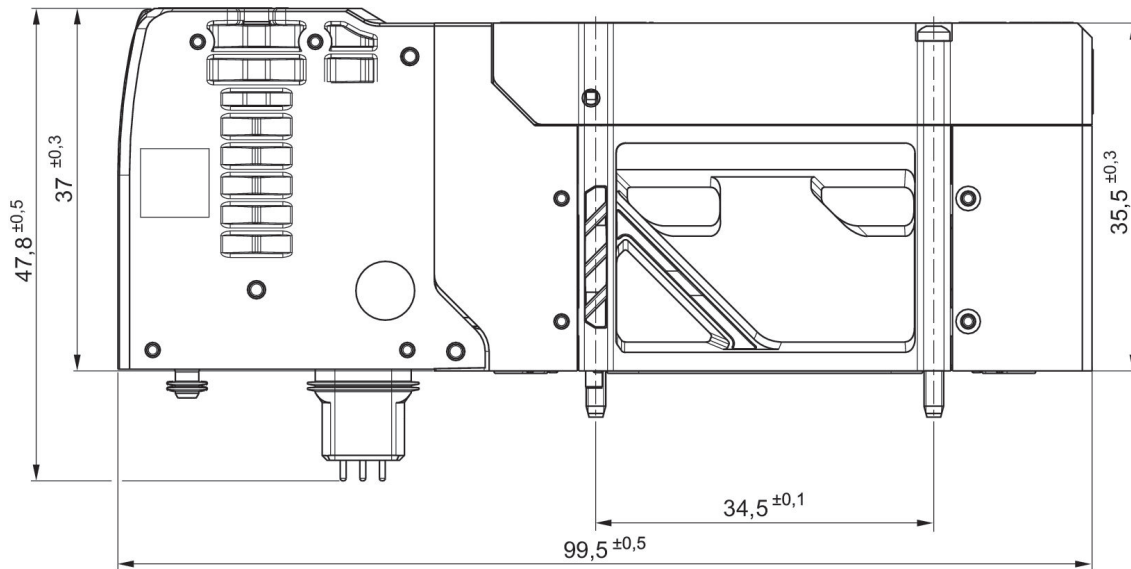

- 1) with detent
- 2) without detent
- 3) Ports: M7

5/2-directional valve, Series XV03, with spring return, Manual override: with detent

Flow: 345 l/min
Activation: Electrically operated
Actuating control: Single Solenoid
Switching principle: 5/2, with spring return

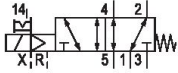

Switching principle	Operational voltage	Pilot	Power consumption DC [W]	Min. working pressure [bar]	Min. working pressure [bar]	Min. control pressure [bar]	Max. control pressure [bar]	Part No.
5/2, with spring return	24 V DC	External	0.55	-0.95	8	3	8	R572A2C10MA00F1

Dimensions

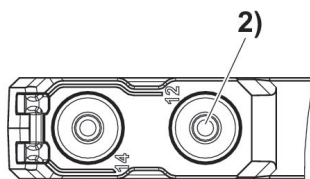
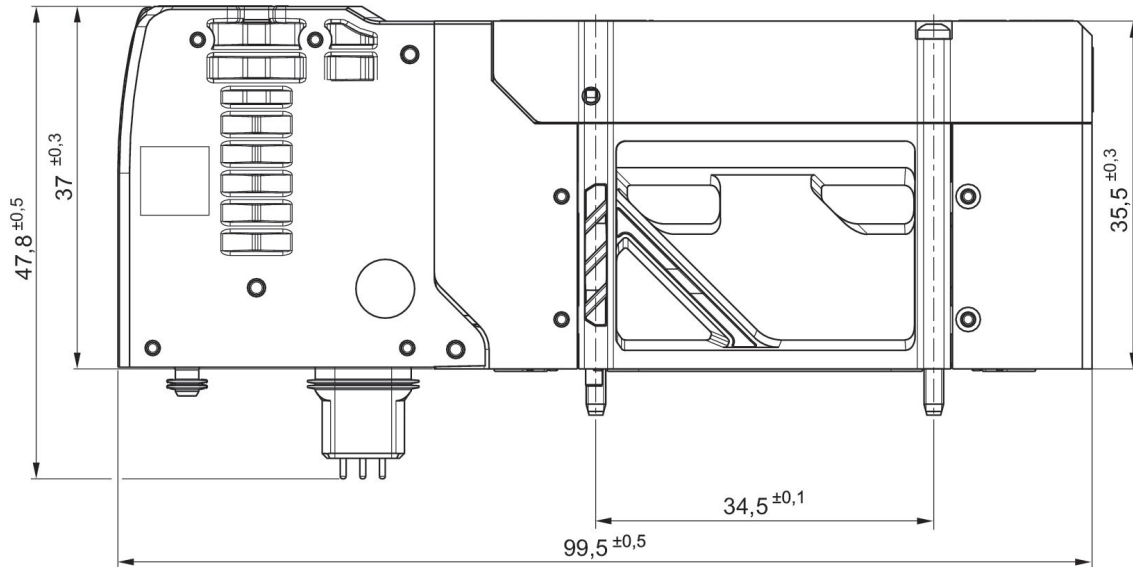

- 1) with detent
- 2) without detent
- 3) Ports: M7

5/2-directional valve, Series XV03, with air spring return, manual override: without detent

Flow: 345 l/min
 Activation: Electrically operated
 Actuating control: Double Solenoid
 Switching principle: 5/2, with air spring return

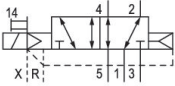

Switching principle	Operational voltage	Pilot	Power consumption DC [W]	Min. working pressure [bar]	Min. working pressure [bar]	Min. control pressure [bar]	Max. control pressure [bar]	Part No.
5/2, with air spring return	24 V DC	External	0.55	-0.95	8	3	8	R572A2B-N0MA00F1

Dimensions

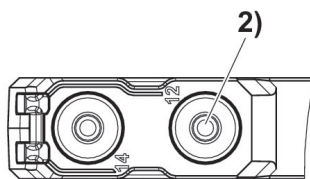
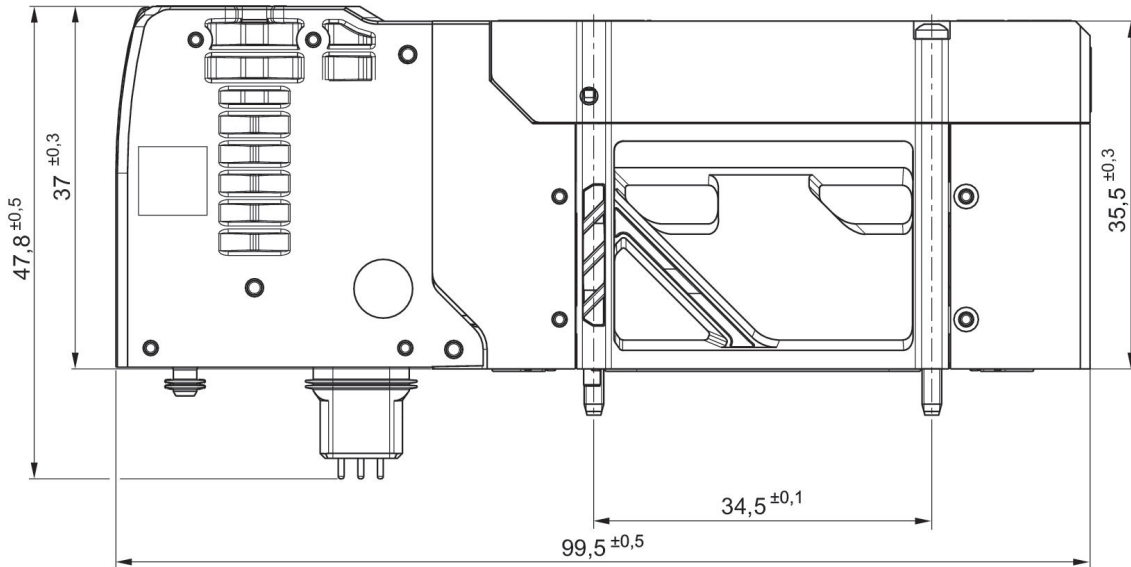

- 1) with detent
- 2) without detent
- 3) Ports: M7

5/2-directional valve, Series XV03, with air spring return, Manual override: with detent

Flow: 330 l/min
 Activation: Electrically operated
 Actuating control: Double Solenoid
 Switching principle: 5/2, with air spring return

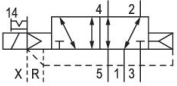

Switching principle	Operational voltage	Pilot	Power consumption DC [W]	Min. working pressure [bar]	Min. working pressure [bar]	Min. control pressure [bar]	Max. control pressure [bar]	Part No.
5/2, with air spring return	24 V DC	External	0.55	-0.95	8	3	8	R572A2C-N0MA00F1

Dimensions

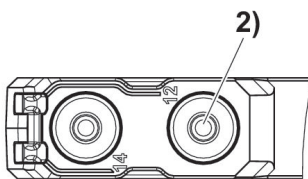
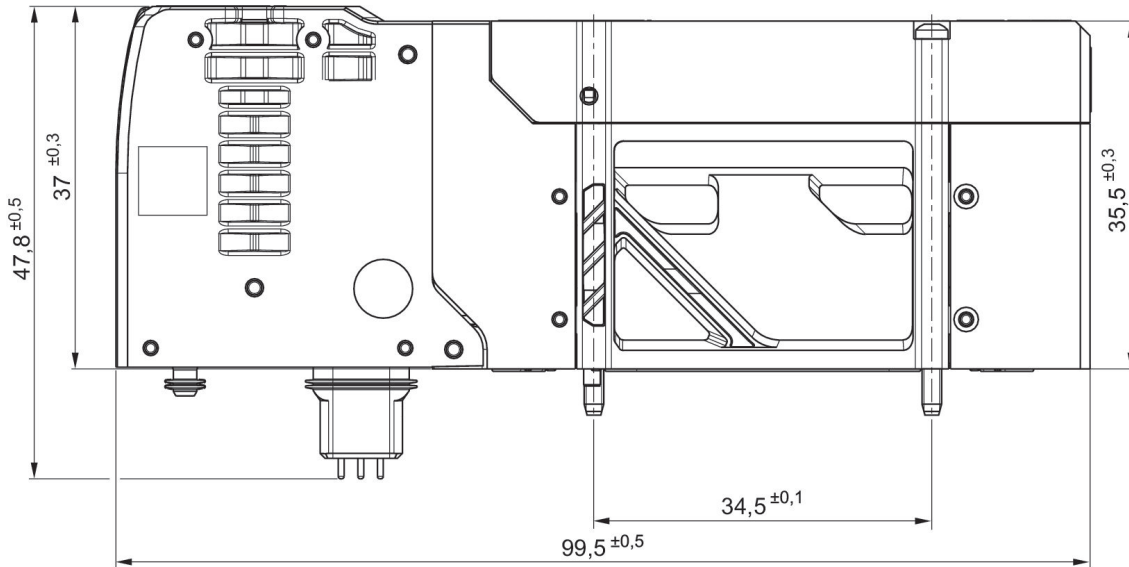

- 1) with detent
- 2) without detent
- 3) Ports: M7

5/2-directional valve, Series XV03, double solenoid, manual override: without detent

Flow: 330 l/min
 Activation: Electrically operated
 Actuating control: Double Solenoid
 Switching principle: 5/2, double solenoid

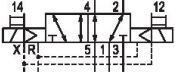

Switching principle	Operational voltage	Pilot	Power consumption DC [W]	Min. working pressure [bar]	Min. working pressure [bar]	Min. control pressure [bar]	Max. control pressure [bar]	Part No.
5/2, double solenoid	24 V DC	External	0.55	-0.95	8	3	8	R572A2B40MA00F1

Dimensions

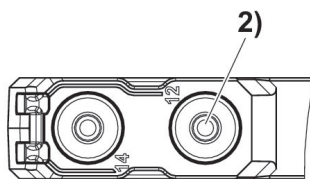
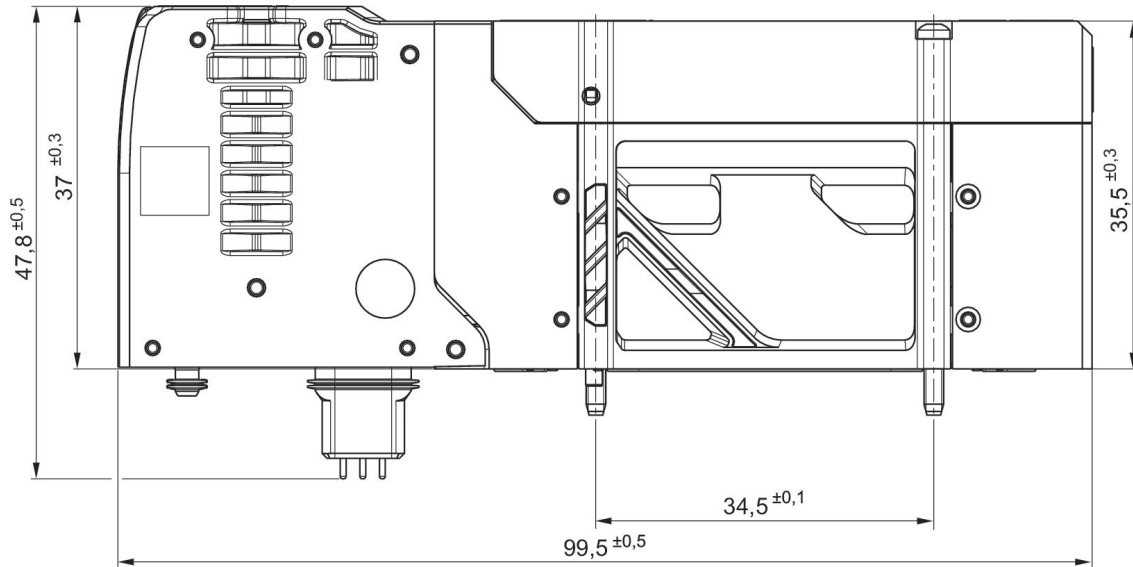

- 1) with detent
- 2) without detent
- 3) Ports: M7

5/2-directional valve, Series XV03, double olenoid, Manual override: with detent

Flow: 330 l/min
 Activation: Electrically operated
 Actuating control: Double Solenoid
 Switching principle: 5/2, double solenoid

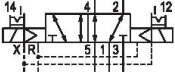

Switching principle	Operational voltage	Pilot	Power consumption DC [W]	Min. working pressure [bar]	Min. working pressure [bar]	Min. control pressure [bar]	Max. control pressure [bar]	Part No.
5/2, double solenoid	24 V DC	External	0.55	-0.95	8	3	8	R572A2C40MA00F1

Dimensions

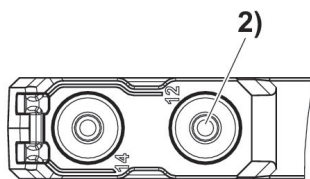
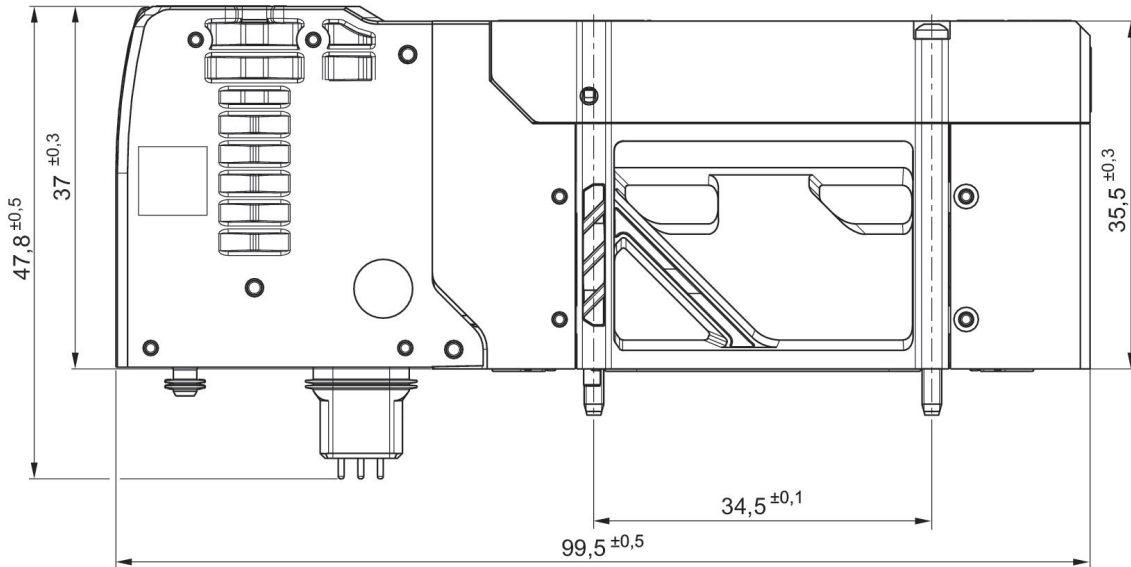

- 1) with detent
- 2) without detent
- 3) Ports: M7

5/3-directional valve, Series XV03, pressurized enter, manual override: without detent

Flow: 350 l/min
 Activation: Electrically operated
 Actuating control: Double Solenoid
 Switching principle: 5/3, pressurized center

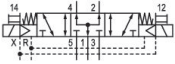

Switching principle	Operational voltage	Pilot	Power consumption DC [W]	Min. working pressure [bar]	Min. working pressure [bar]	Min. control pressure [bar]	Max. control pressure [bar]	Part No.
5/3, pressurized center	24 V DC	External	0.55	-0.95	8	3	8	R572A2B50MA00F1

Dimensions

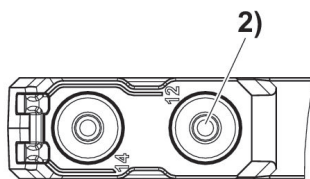
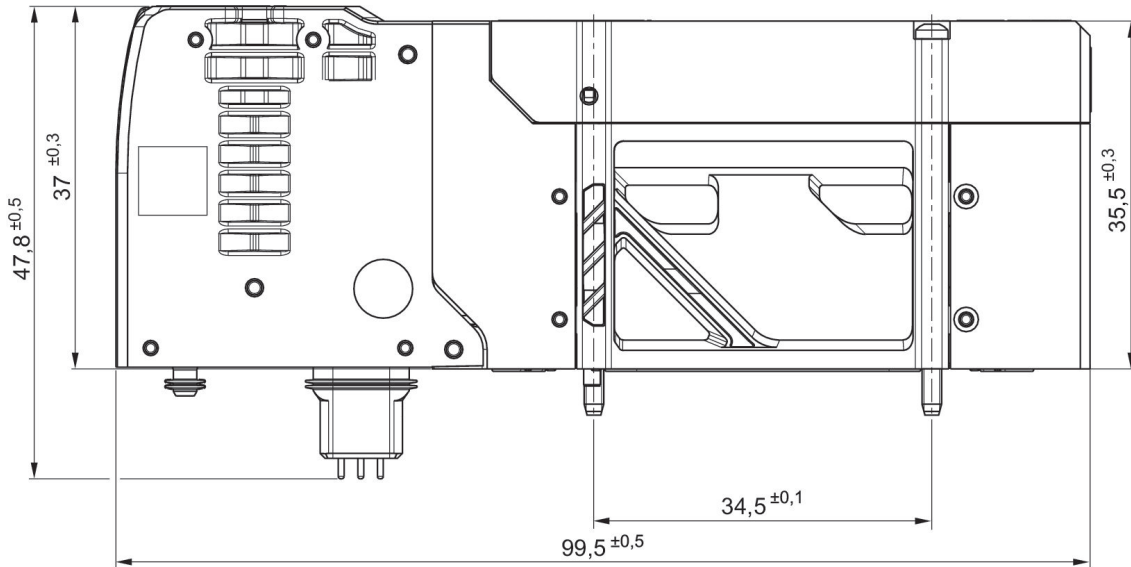

- 1) with detent
- 2) without detent
- 3) Ports: M7

5/3-directional valve, Series XV03, pressurized center, Manual override: with detent

Flow: 350 l/min
 Activation: Electrically operated
 Actuating control: Double Solenoid
 Switching principle: 5/3, pressurized center

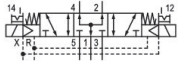

Switching principle	Operational voltage	Pilot	Power consumption DC [W]	Min. working pressure [bar]	Min. working pressure [bar]	Min. control pressure [bar]	Max. control pressure [bar]	Part No.
5/3, pressurized center	24 V DC	External	0.55	-0.95	8	3	8	R572A2C50MA00F1

Dimensions

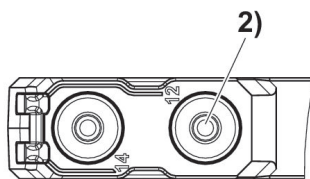
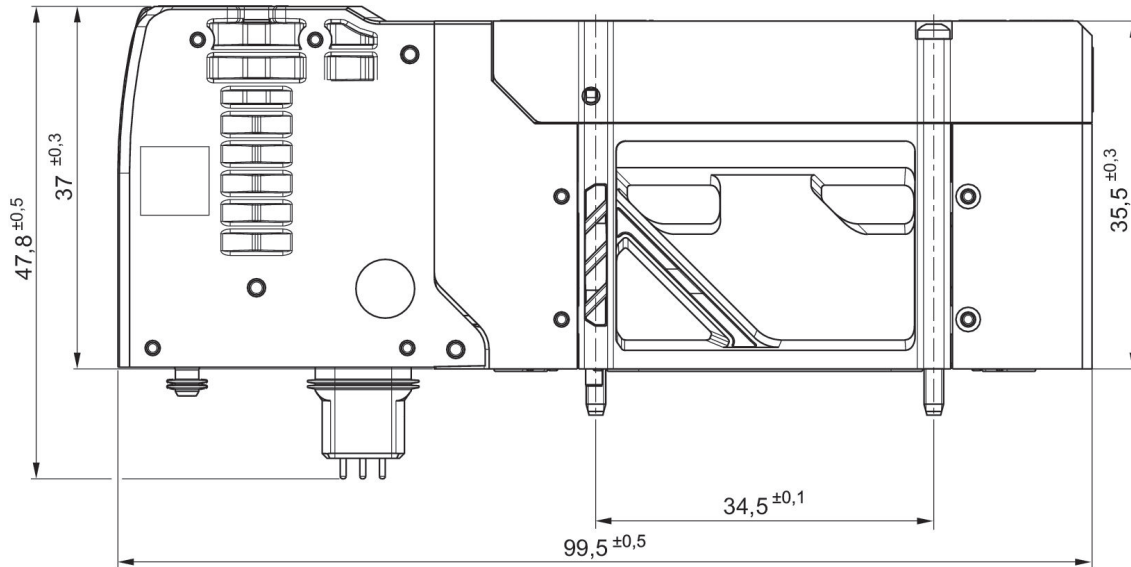

- 1) with detent
- 2) without detent
- 3) Ports: M7

5/3-directional valve, Series XV03, exhausted center, manual override: without detent

Flow: 330 l/min
 Activation: Electrically operated
 Actuating control: Double Solenoid
 Switching principle: 5/3, exhausted center

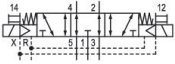

Switching principle	Operational voltage	Pilot	Power consumption DC [W]	Min. working pressure [bar]	Min. working pressure [bar]	Min. control pressure [bar]	Max. control pressure [bar]	Part No.
5/3, exhausted center	24 V DC	External	0.55	-0.95	8	3	8	R572A2B70MA00F1

Dimensions

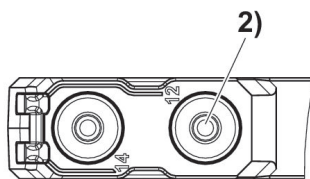
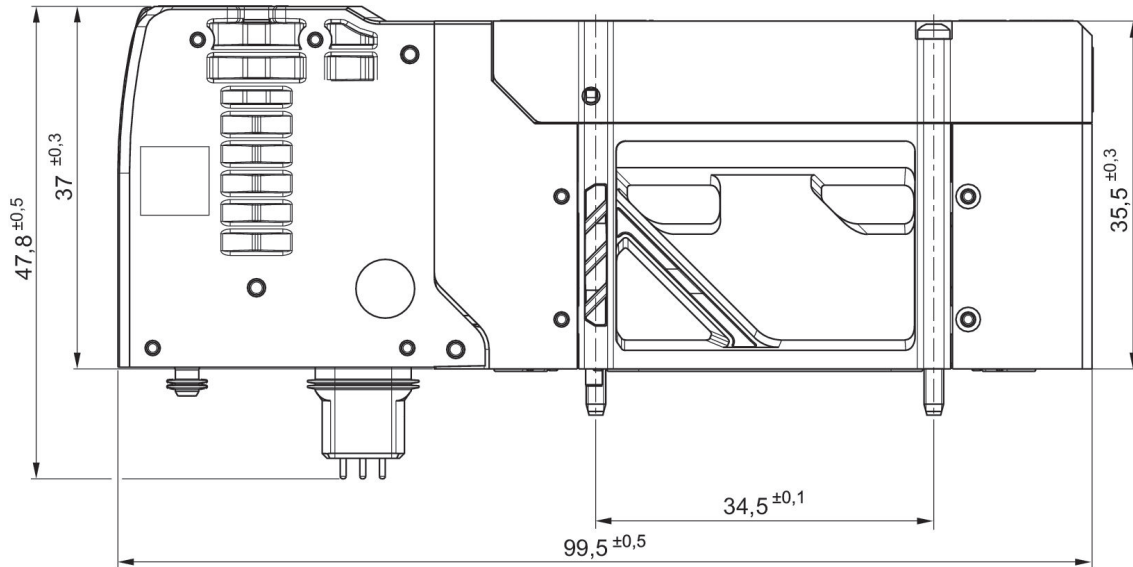

- 1) with detent
- 2) without detent
- 3) Ports: M7

5/3-directional valve, Series XV03, Exhausted Center, Manual override: with detent

Flow: 330 l/min
 Activation: Electrically operated
 Actuating control: Double Solenoid
 Switching principle: 5/3, exhausted center

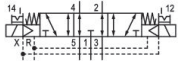

Switching principle	Operational voltage	Pilot	Power consumption DC [W]	Min. working pressure [bar]	Min. working pressure [bar]	Min. control pressure [bar]	Max. control pressure [bar]	Part No.
5/3, exhausted center	24 V DC	External	0.55	-0.95	8	3	8	R572A2C70MA00F1

Dimensions

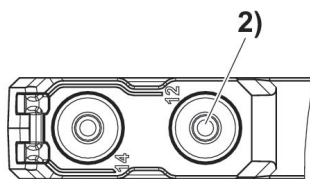
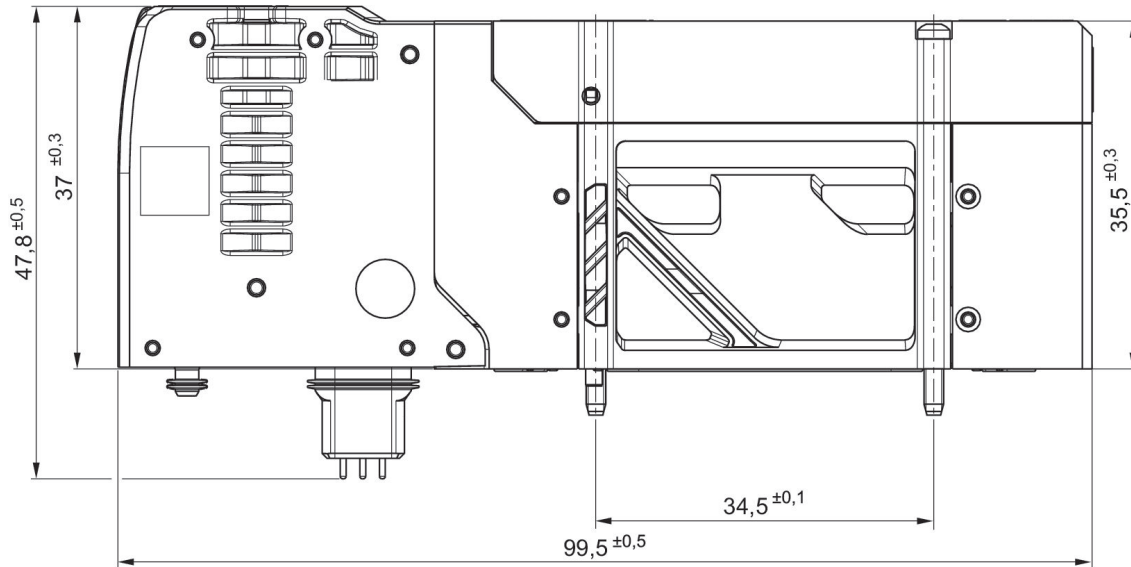

- 1) with detent
- 2) without detent
- 3) Ports: M7

5/3-directional valve, Series XV03, closed center, manual override: without detent

Flow: 280 l/min
 Activation: Electrically operated
 Actuating control: Double Solenoid
 Switching principle: 5/3, closed center

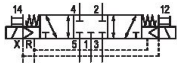

Switching principle	Operational voltage	Pilot	Power consumption DC [W]	Min. working pressure [bar]	Min. working pressure [bar]	Min. control pressure [bar]	Max. control pressure [bar]	Part No.
5/3, closed center	24 V DC	External	0.55	-0.95	8	3	8	R572A2B60MA00F1

Dimensions

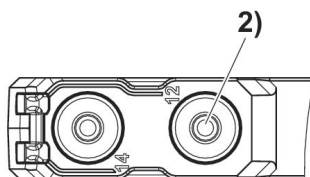
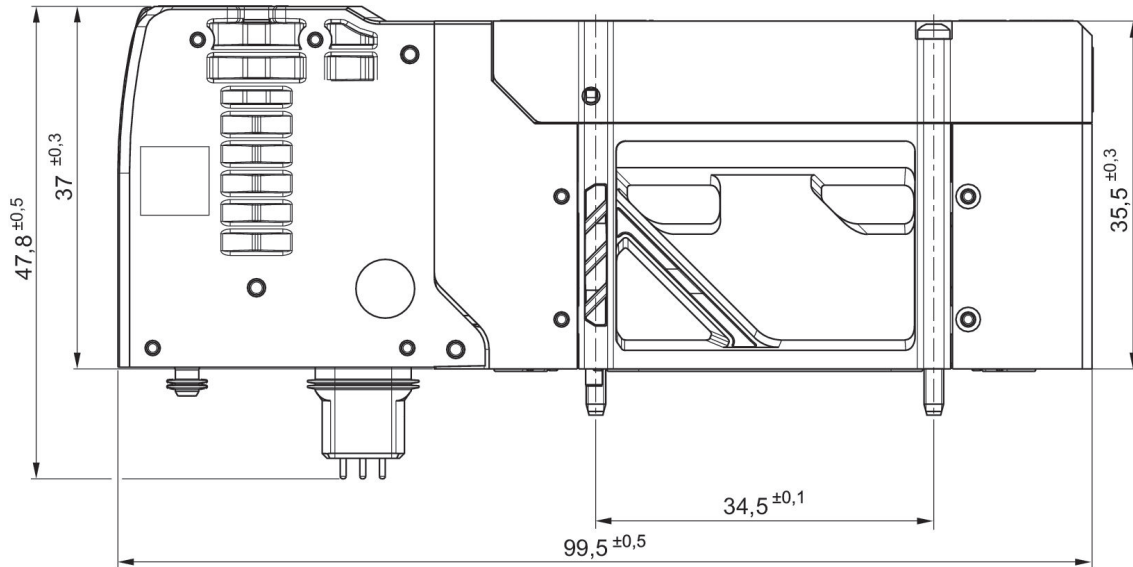

- 1) with detent
- 2) without detent
- 3) Ports: M7

5/3-directional valve, Series XV03, closed center, Manual override: with detent

Flow: 280 l/min
 Activation: Electrically operated
 Actuating control: Double Solenoid
 Switching principle: 5/3, closed center

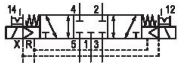

Switching principle	Operational voltage	Pilot	Power consumption DC [W]	Min. working pressure [bar]	Min. working pressure [bar]	Min. control pressure [bar]	Max. control pressure [bar]	Part No.
5/3, closed center	24 V DC	External	0.55	-0.95	8	3	8	R572A2C60MA00F1

Dimensions

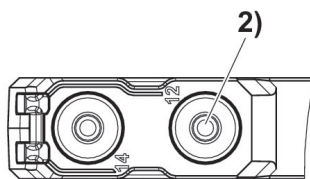
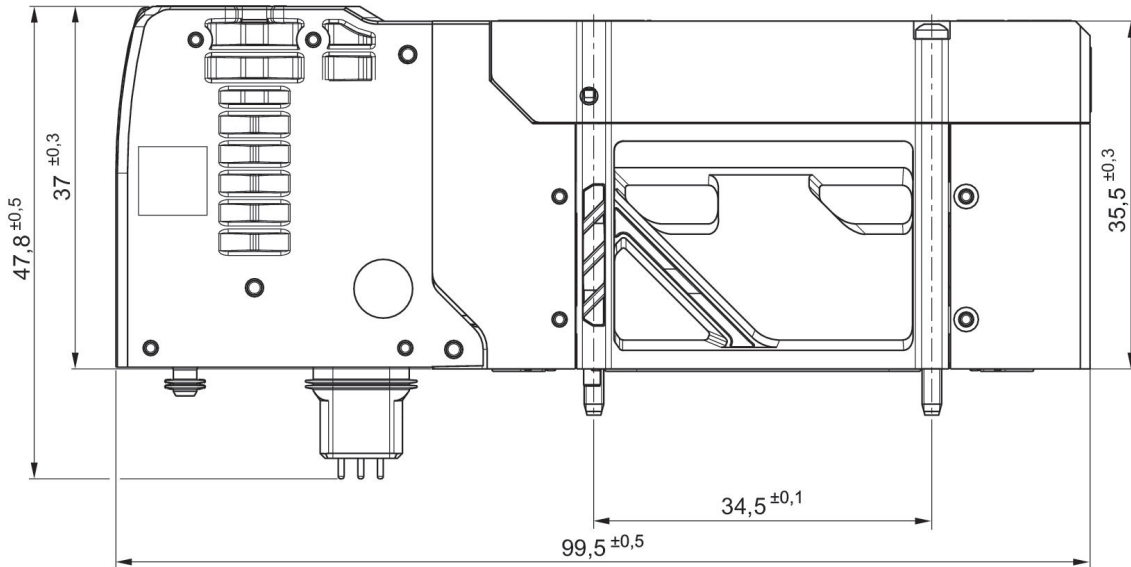

- 1) with detent
- 2) without detent
- 3) Ports: M7

Bus coupler, series XVES Profinet



Fieldbus protocol	Power plug IN, Type	Power plug IN size , Thread size	Power plug IN, Number of poles	Number of I/O connections	Part No.
Profinet	Plug (male)	M12x1	4-pin	48 outputs	P570ABPN1011A00

Dimensions

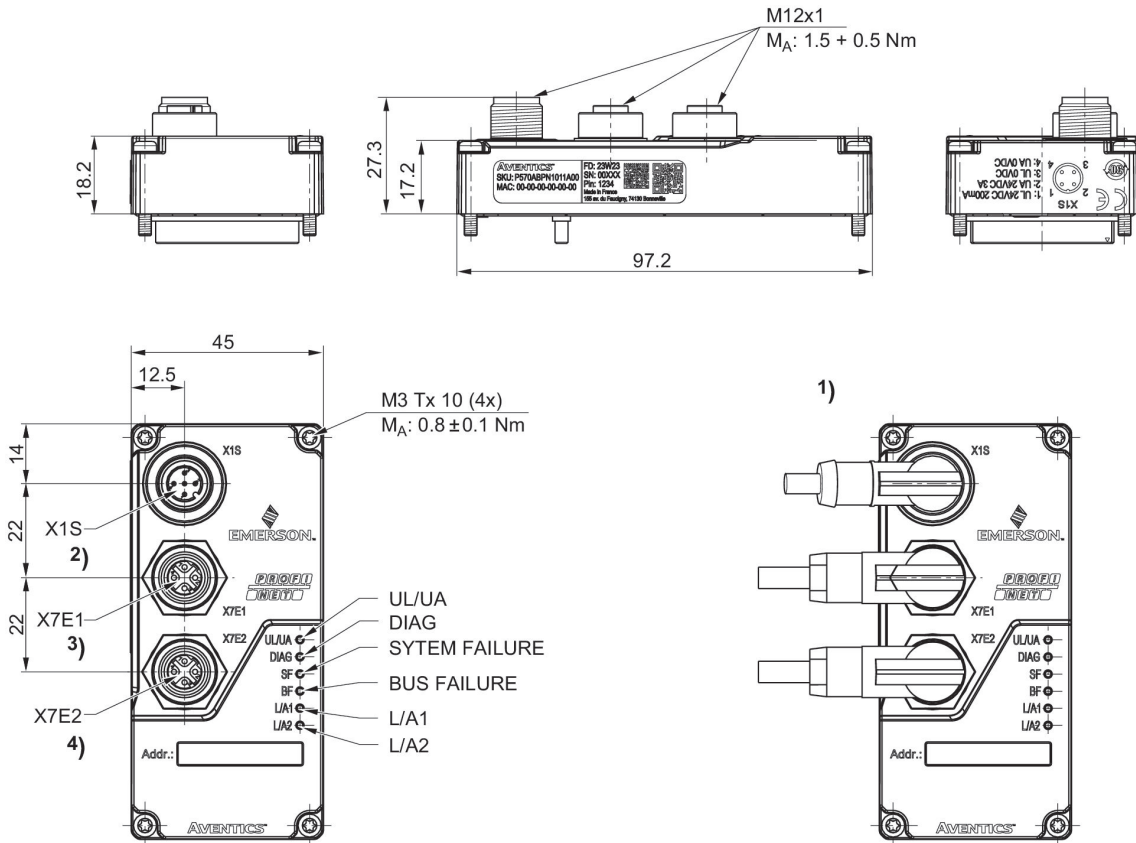

- 1) Cable exit direction – angle plug
- 2) Power plug
- 3) Communication port 1
- 4) Communication port 2

P570ABPN1011A00

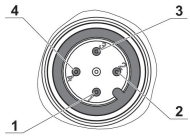

X1S

Pin	
1	TD+
2	RD+
3	TD-
4	RD-

Bus coupler, series XVES EtherCAT



Fieldbus protocol	Power plug IN, Type	Power plug IN size , Thread size	Power plug IN, Number of poles	Number of I/O connections	Part No.
EtherCAT	Plug (male)	M12x1	4-pin	48 outputs	P570ABEC1011A00

Dimensions

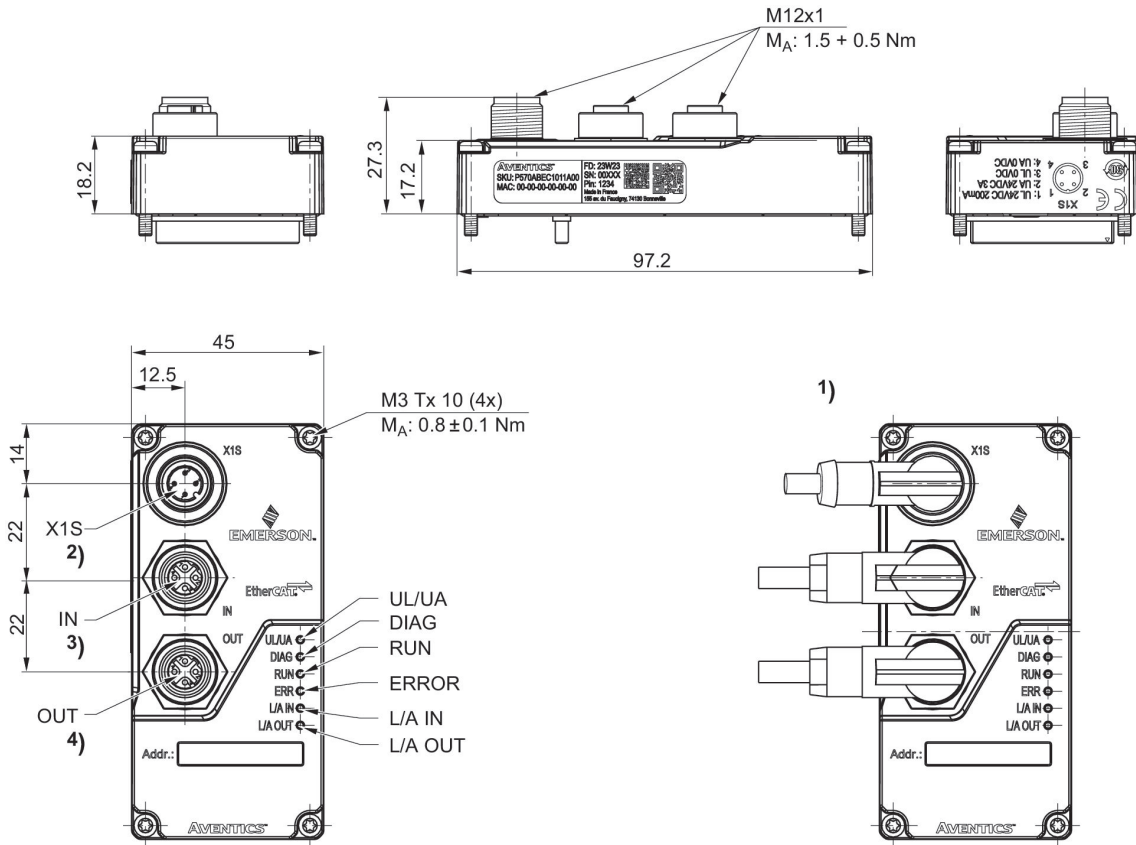

- 1) Cable exit direction – angle plug
- 2) Power plug
- 3) Communication port 1
- 4) Communication port 2

P570ABEC1011A00

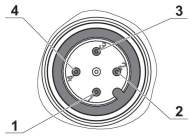

X1S

Pin	
1	TD+
2	RD+
3	TD-
4	RD-

Bus coupler, series XVES EtherNet/IP



Fieldbus protocol	Power plug IN, Type	Power plug IN size , Thread size	Power plug IN, Number of poles	Number of I/O connections	Part No.
EtherNet/IP	Plug (male)	M12x1	4-pin	48 outputs	P570ABED1011A00

Dimensions

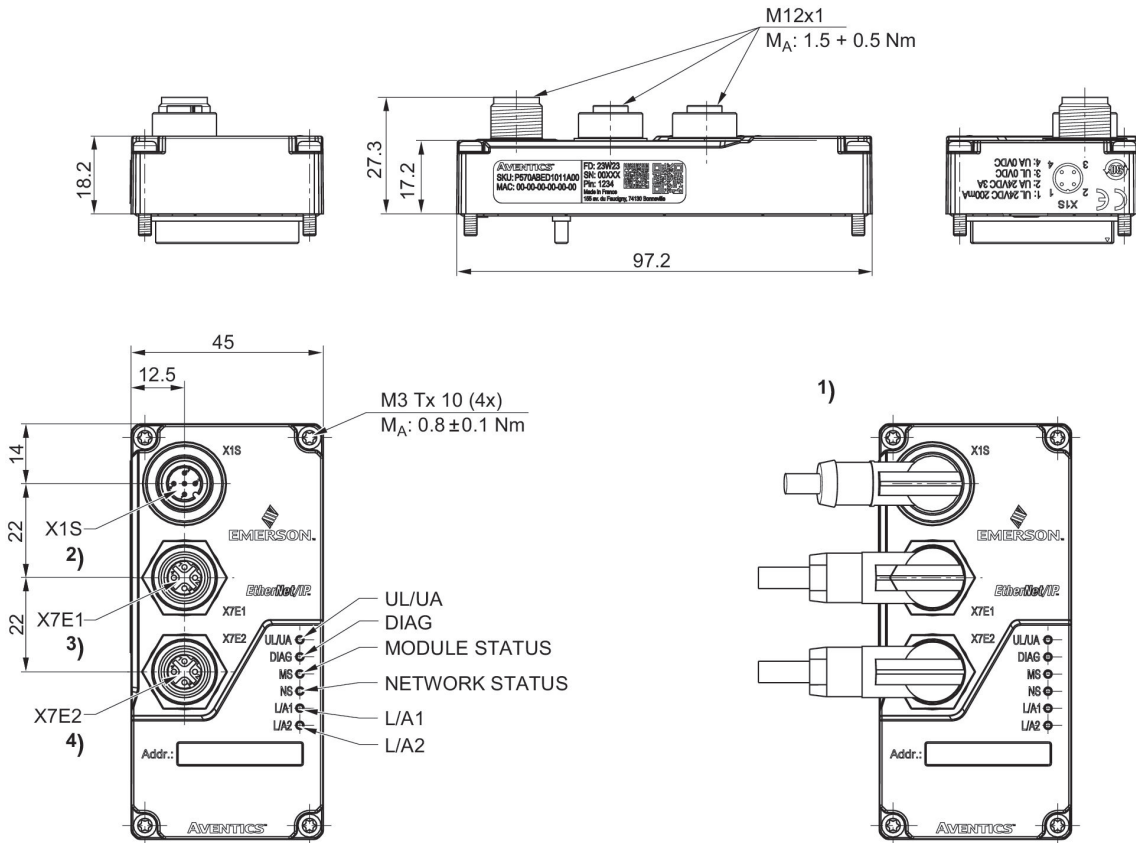

- 1) Cable exit direction – angle plug
- 2) Power plug
- 3) Communication port 1
- 4) Communication port 2

P570ABED1011A00

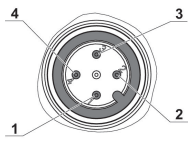

X1S

Pin	
1	TD+
2	RD+
3	TD-
4	RD-

Bus coupler, series XVES Modbus TCP



Fieldbus protocol	Power plug IN, Type	Power plug IN size , Thread size	Power plug IN, Number of poles	Number of I/O connections	Part No.
MODBUS TCP	Plug (male)	M12x1	4-pin	48 outputs	P570ABE-M1011A00

Dimensions

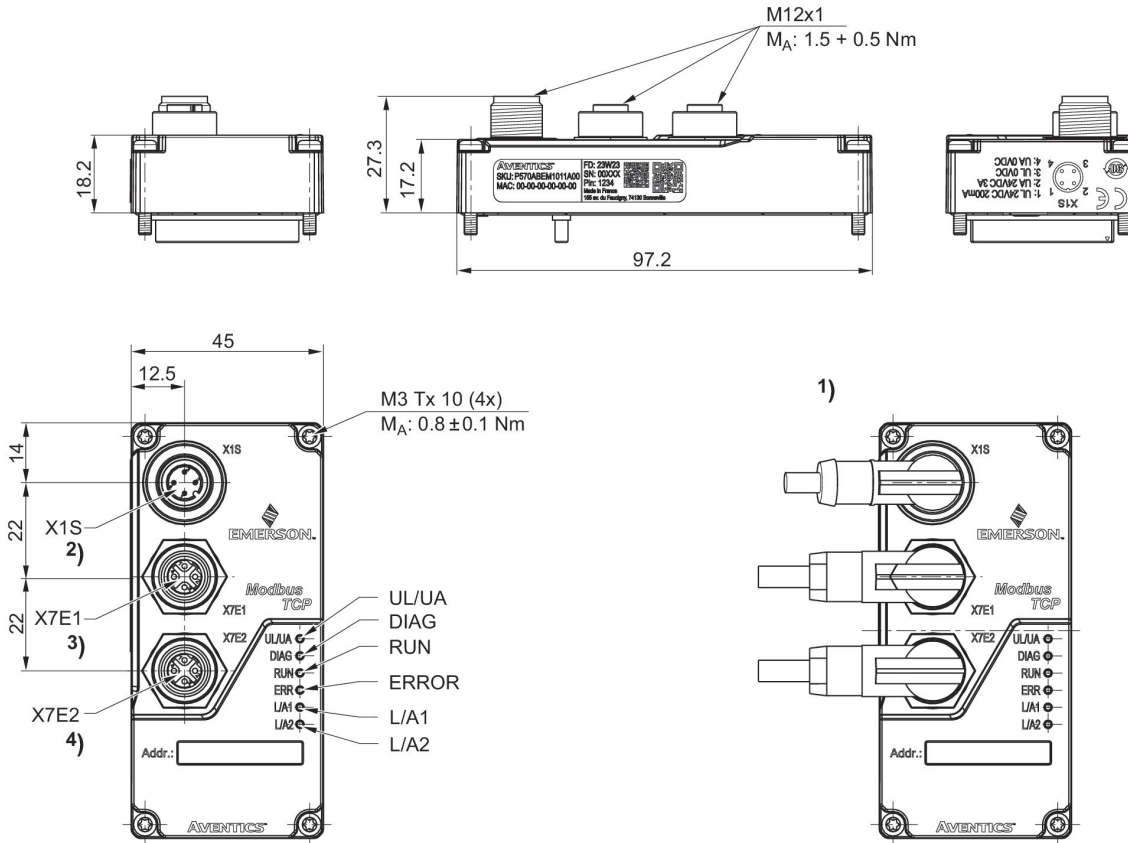

- 1) Cable exit direction – angle plug
- 2) Power plug
- 3) Communication port 1
- 4) Communication port 2

P570ABEM1011A00

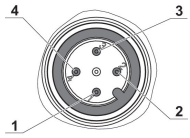

X1S

Pin	
1	TD+
2	RD+
3	TD-
4	RD-

Bus coupler, series XVES Profibus DP

Electrical connection 2, type: Plug

Electrical connection 2, thread size: M12x1

Electrical connection 2, number of poles: 4-pin



Fieldbus protocol	Power plug IN, Type	Power plug IN size, Thread size	Power plug IN, Number of poles	Number of I/O connections	Part No.
PROFIBUS DP	Plug	M12x1	4-pin	48 outputs	P570ABPB1011A00

Dimensions

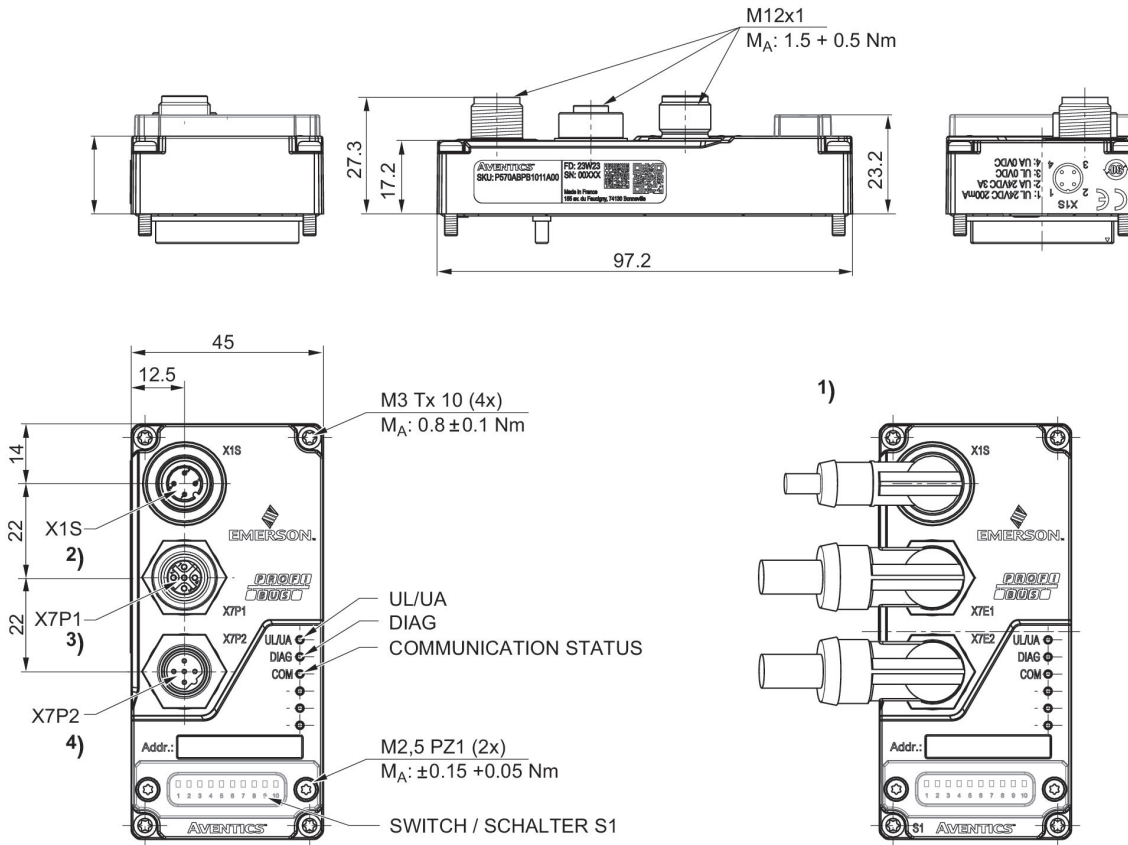

- 1) Cable exit direction – angle plug
- 2) Power plug
- 3) Communication port 1
- 4) Communication port 2

P570ABPB1011A00

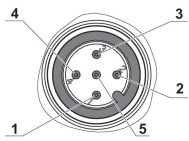

X7P2

Pin	
1	-
2	A-data line
3	-
4	B-data line
5	FE

Bus coupler, series XVES IO-Link

Electrical connection 2, type: Plug

Electrical connection 2, thread size: M12x1

Electrical connection 2, number of poles: 4-pin



Fieldbus protocol	Power plug IN, Type	Power plug IN size , Thread size	Power plug IN, Number of poles	Number of I/O connections	Part No.
IO-Link	Plug	M12x1	4-pin	48 outputs	P570ABLKA010A00
IO-Link, type B	Plug	M12x1	5-pin	48 outputs	P570ABLKB010A00
IO-Link type AB	Plug	M12x1	4-pin	48 outputs	P570ABLM5010A00

Dimensions

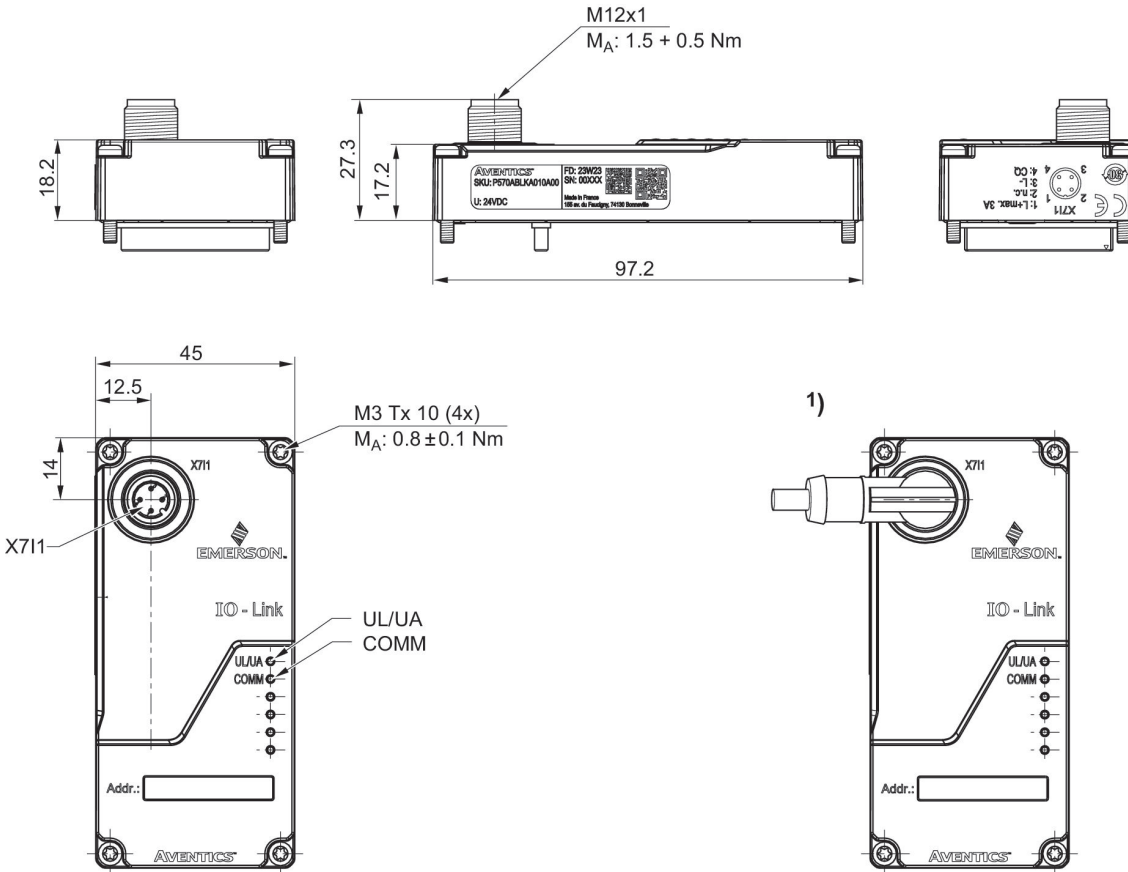

1) Cable exit direction – angle plug

P570ABLKA010A00, P570ABLM5010A00

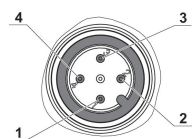

X711

Pin	
1	L+ 24 V DC
2	-
3	L-
4	CQ (IO link data)

P570ABLKB010A00

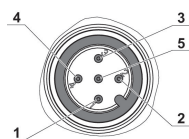

X711

Pin	
1	L+ 24 V DC
2	2L+ 24 V DC
3	L-
4	CQ (IO link data)
5	2 L-

Multipole connection, 25-pin, on top



Max. number of solenoid coils	Weight [kg]	Part No.
24	0.06	P570AAP251D0A00

Dimensions

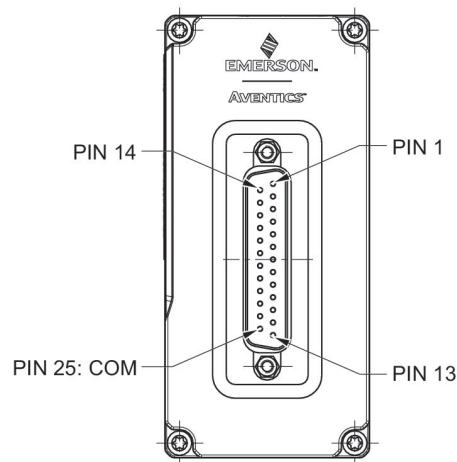
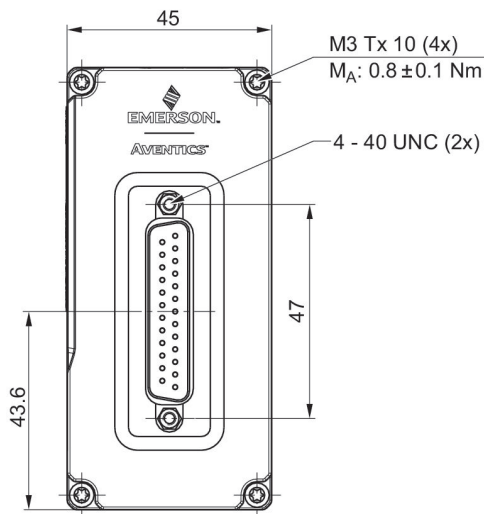
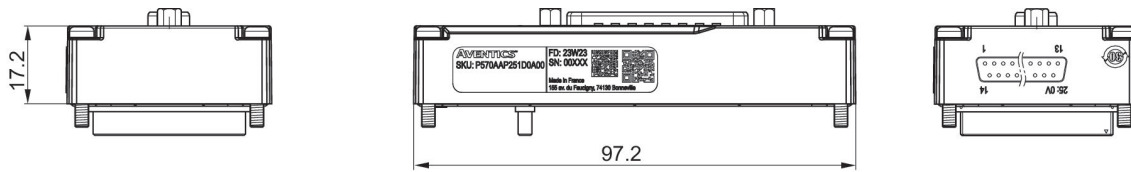

Multipole connection, 44-pin, on top



Max. number of solenoid coils	Weight [kg]	Part No.
42	0.08	P570AAP441D0A00

Dimensions

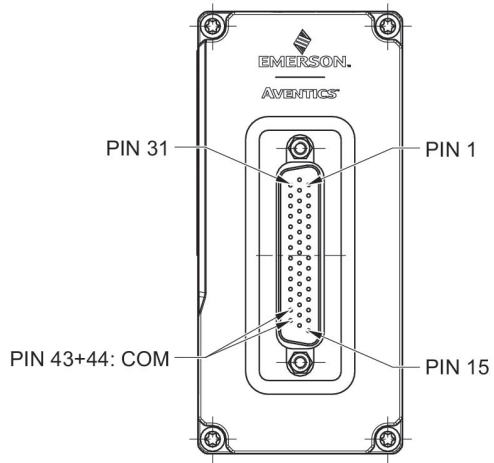
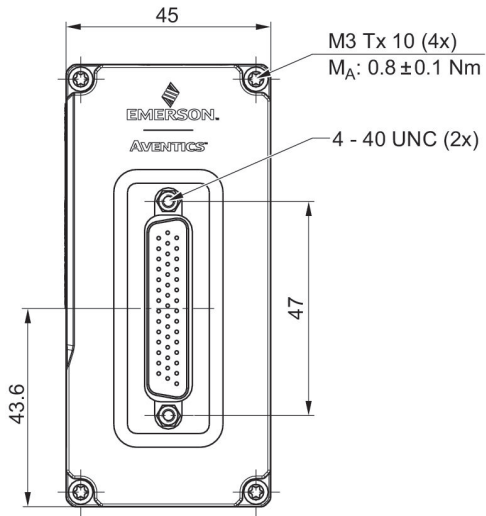
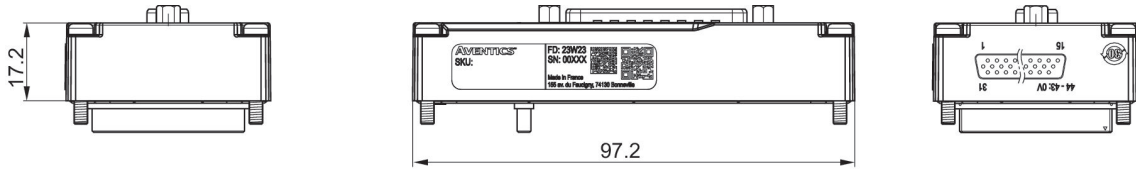

Multipole connection, 25-pin, on the side



Max. number of solenoid coils	Weight [kg]	Part No.
24	0.08	P570AAP251E0A00

Dimensions

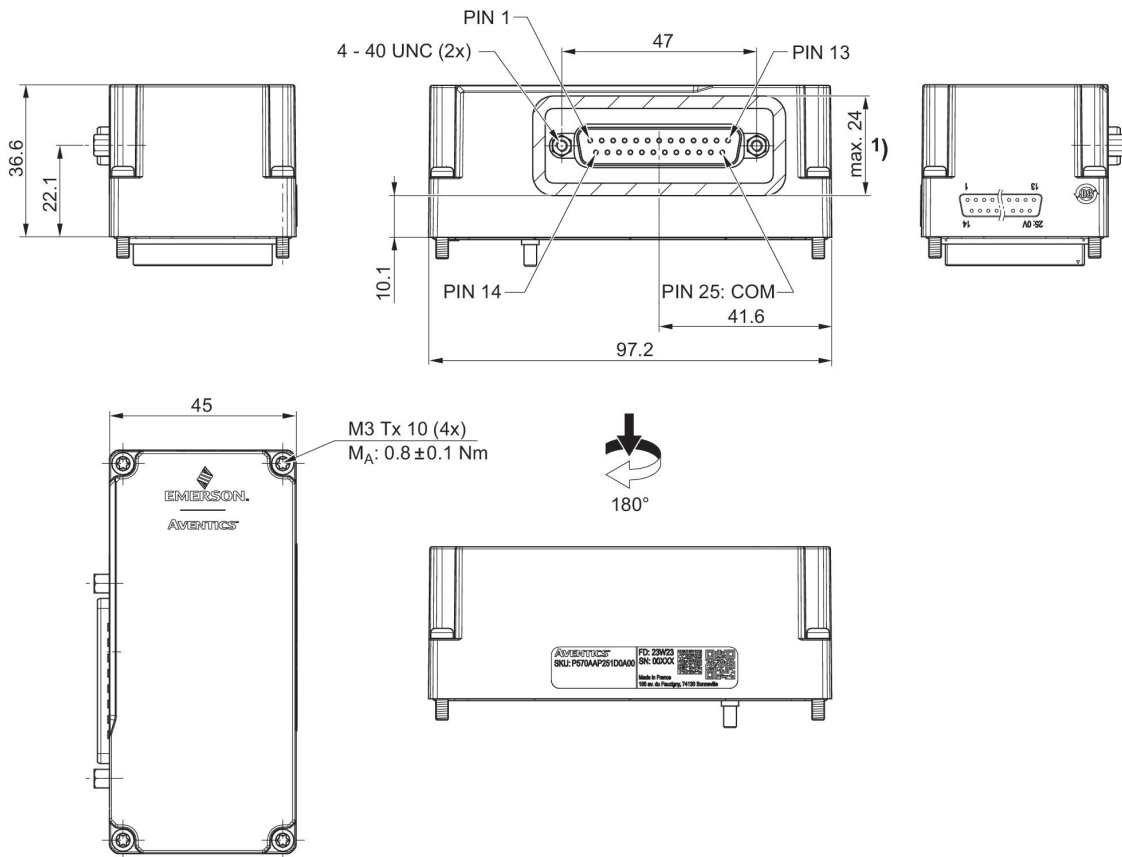

1) For D-Sub plug

Multipole connection, 44-pin, on the side



Max. number of solenoid coils	Weight [kg]	Part No.
42	0.08	P570AAP441E0A00

Dimensions

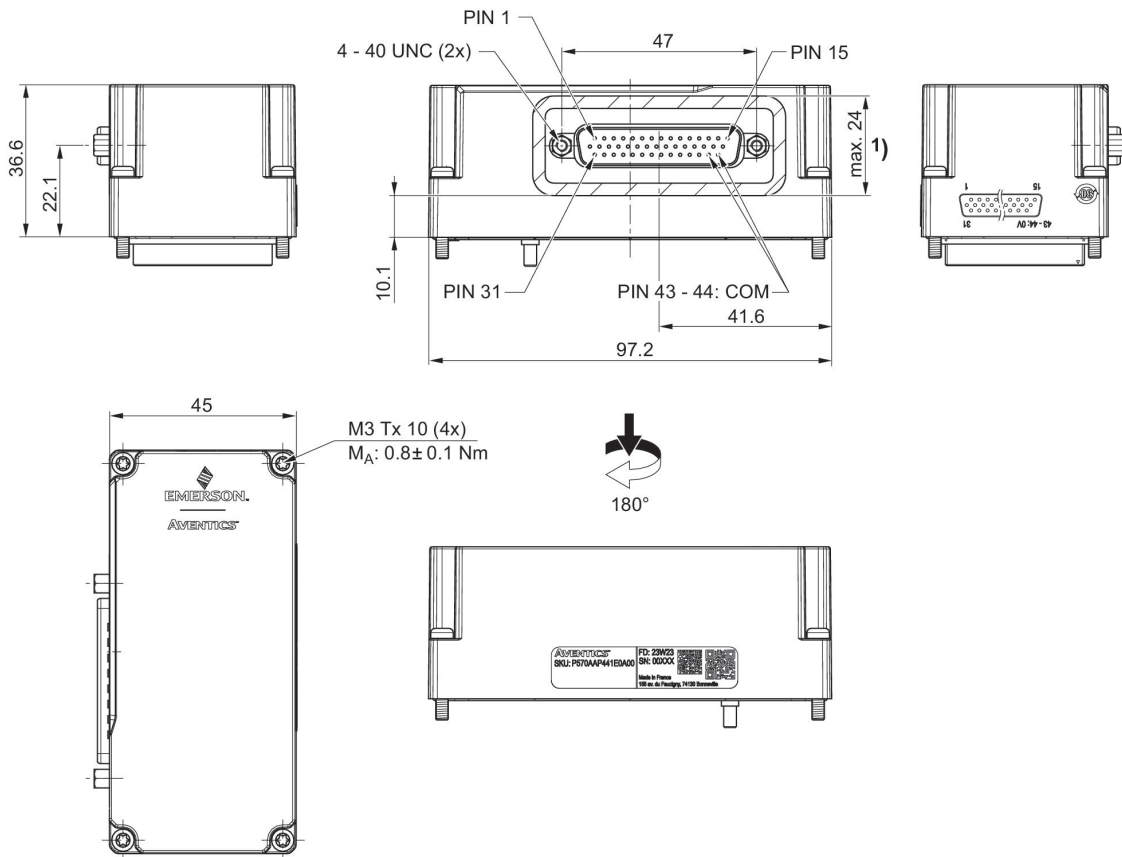

1) For D-Sub plug

Multipole connection, terminal 27, on top

Certificates: RoHS



Max. number of solenoid coils	Weight [kg]	Part No.
24	0.06	P570AAP271S0A00

Dimensions

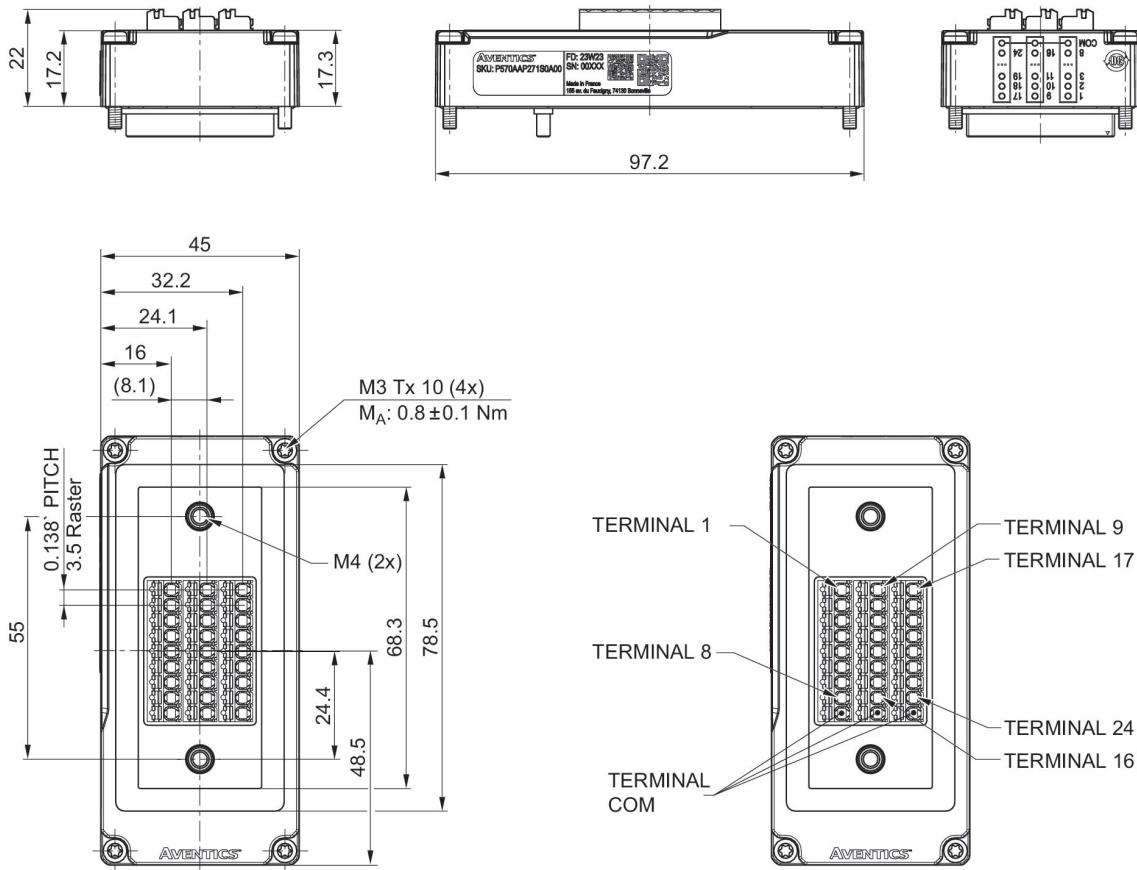

Supply plate, series XV03



Max. number of valve positions	Part No.
1	H572AZ562822001

Dimensions

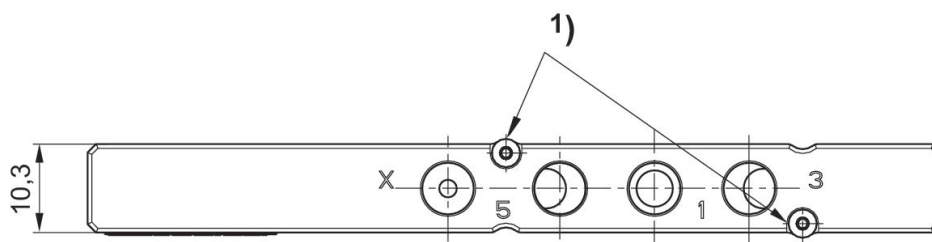
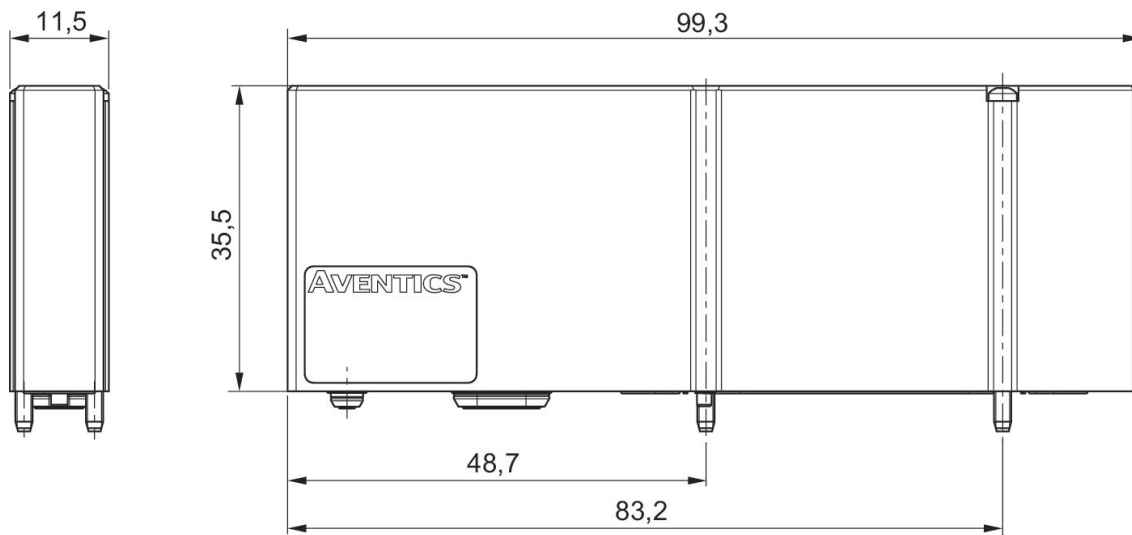

1) Tightening torque: 2 Nm ±0.2

Blank plate, series XV03



Type	Plate type	Scope of delivery	Max. number of valve positions	Part No.
Blanking plate	Blanking plate	Blank plate, sealing kit, mounting screws	1	R572AB555872001

Dimensions

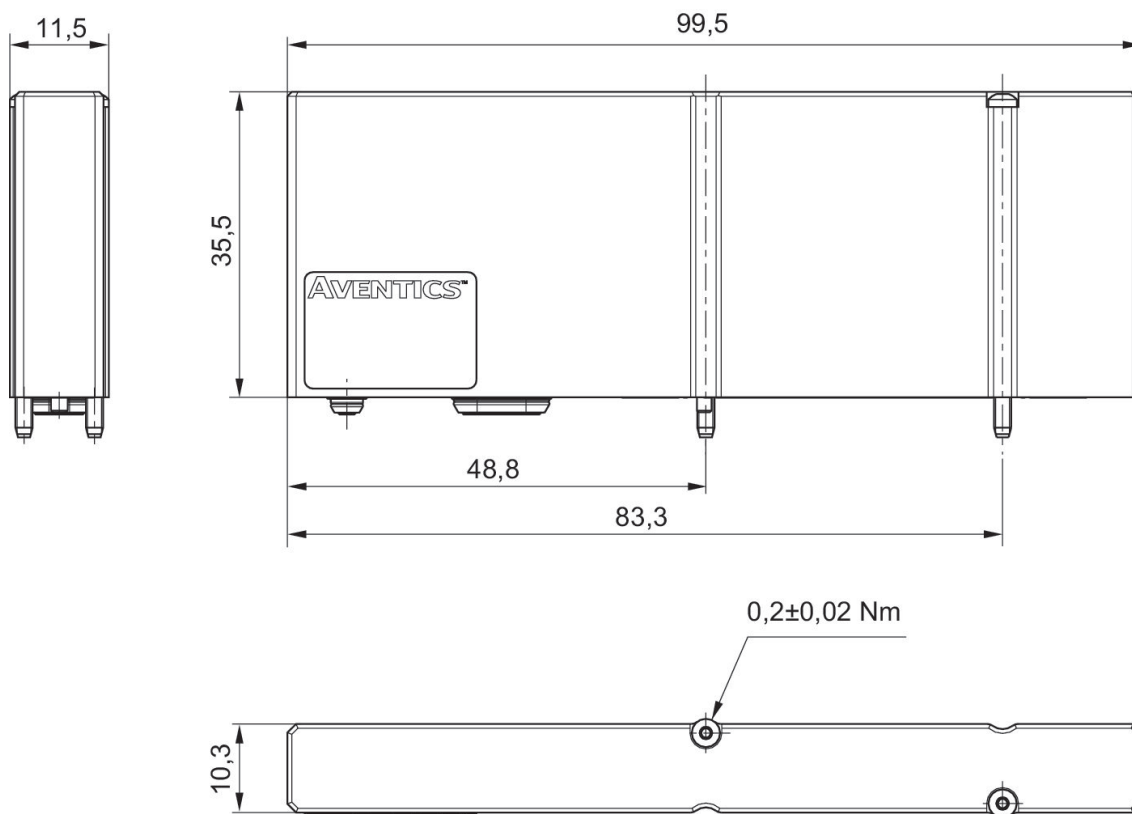

Air supply sandwich plate, series XV03



Scope of delivery	Max. number of valve positions	Part No.
Sandwich plate, sealing kit, mounting screws	1	H572AW555464001

Dimensions

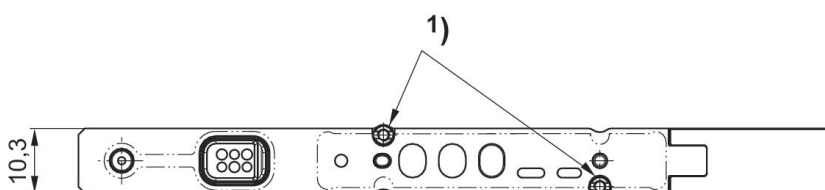
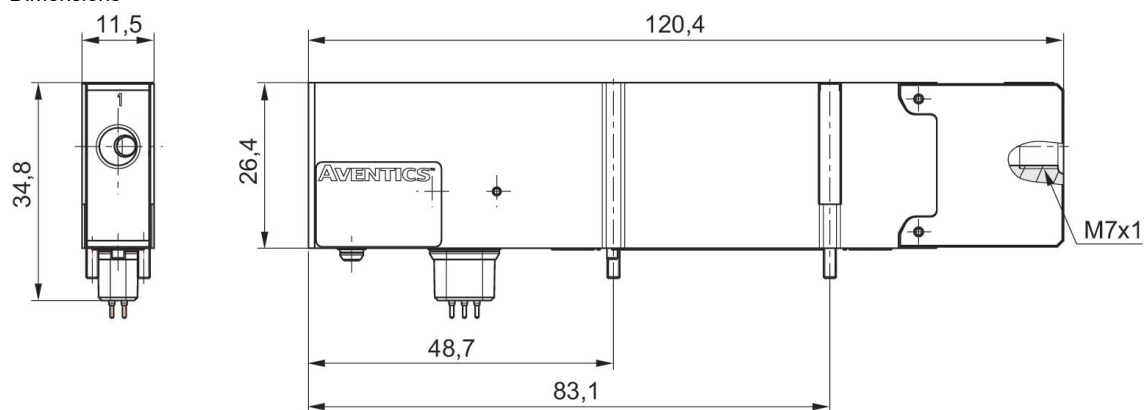

1) Tightening torque: 2 Nm ±0.2

Exhaust sandwich plate, series XV03



Scope of delivery	Max. number of valve positions	Part No.
Sandwich plate, sealing kit, mounting screws	1	H572AX555465001

Dimensions

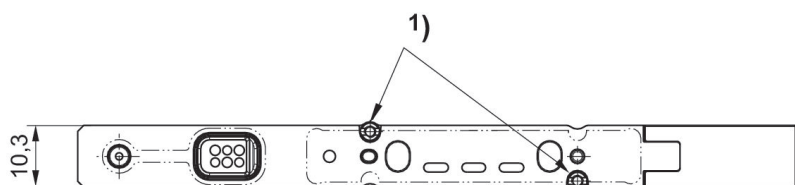
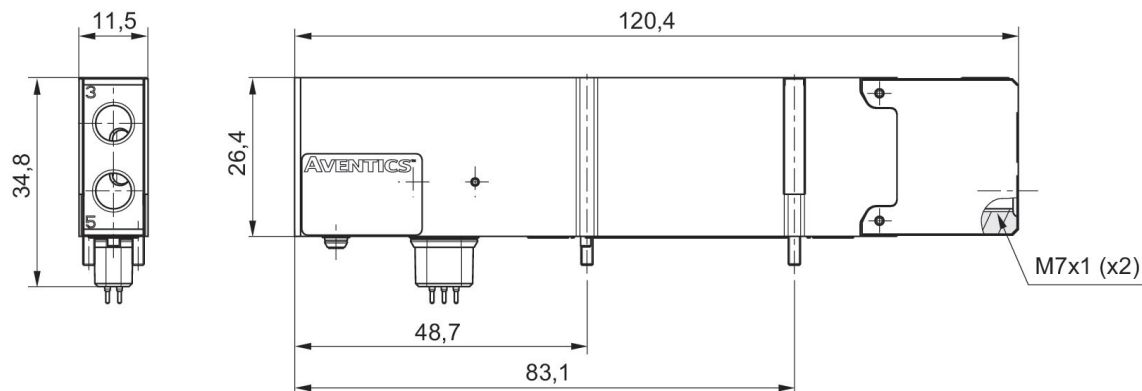

1) Tightening torque: 2 Nm ±0.2

