

STAINLESS STEEL INTEGRATED MOTOR ACTUATOR

IMA-S

The IMA-S is a hygienically designed integrated servo actuator for the food and beverage processing industry. The IMA-SA option incorporates an internal anti-rotate feature. Clean-in-place compatibility and the hygienic features of the IMA-S make it the perfect actuator for applications such as volumetric filling and pumping.

EFFICIENT INTEGRATED MOTOR DESIGN

- Skewed winding minimizes cogging torque for smooth, repeatable motion
- Low electric time constant motor for quick response
- Power dense

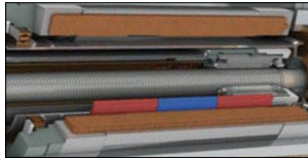

STAINLESS STEEL DESIGN

- 316 Stainless steel construction
- Superior corrosion resistance

GREASE PORT

- Integrated into rod end for hygienic design
- Screw re-lubrication system via needle zerk extends screw service life

WELDED JOINTS

Welded, polished joints create the most hygienic seam

BLUE GASKETS & O-RINGS

- Chemically inert
- Wear resistant
- FDA approved

FLEXIBLE FEEDBACK & CABLE OPTIONS



Single (DSL) and dual cable options

MULTIPLE SCREW TECHNOLOGIES

- Ball screws provide efficient motion at an economical price
- Roller screws provide the highest force and longest life



ADDITIONAL OPTIONS

- Brake
- Externally threaded rod end
- Front flange mount
- Rear clevis mount
- Hygienic fasteners
- FDA approved seal cartridge

FIELD REPLACEABLE SEAL CARTRIDGE

- IP69K rated, wash-down protection
- Clean-in-place compatible
- FDA approved seal cartridge option

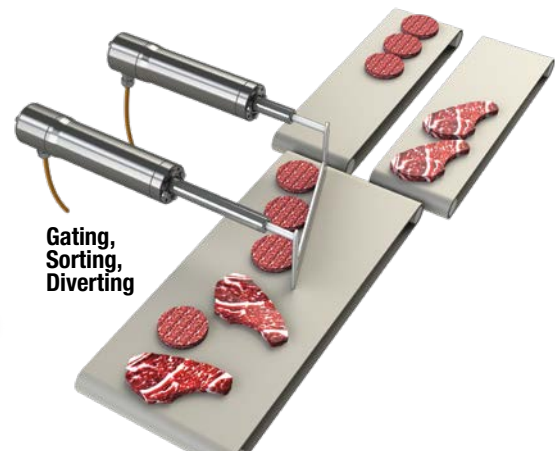
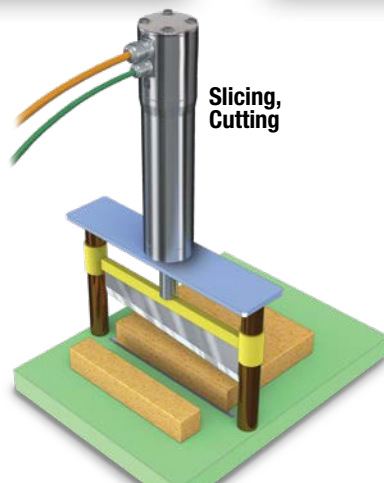

RODLESS SCREW-DRIVE ELECTRIC ACTUATOR

IMA-S

Dimensions:

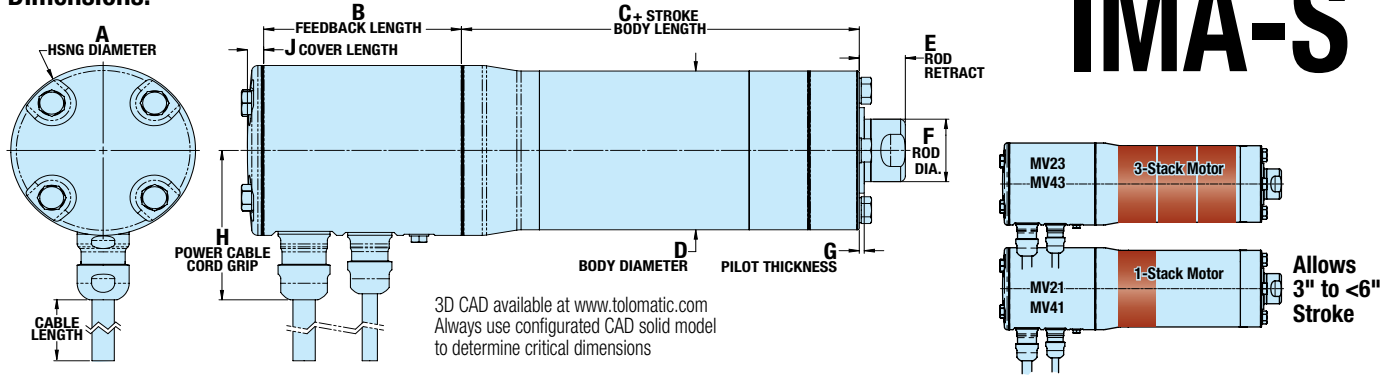

	ST22	ST33	SA33
A	3.00	3.75	3.75
B min.	3.45	3.15	3.15
B max.	5.62	5.51	5.51
C1 min.	4.87	6.25	15.02
C2 max.	4.97	6.35	15.12
D	2.52	3.50	3.50
E2 min.	0.62	0.83	0.83
E1 max.	0.72	0.93	0.93
F	0.999	1.378	1.378

Dimensions in inches

	ST22	ST33	SA33
G *	0.100	0.100	0.100
H †	2.90	3.30	3.30
J	0.32	0.33	0.33

B varies depending on feedback device chosen
C1(min.) for standard actuator; C2(max.) for actuator with PCD option
E2(min.) for actuator with PCD option; E1(max.) for standard actuator

* Not compatible with PCD option

† Only 1 cord grip required with Sick Hiperface DSL (no "S", separate feedback cable);
22 size (74.9 mm [2.99"]); 33 size (85.4 mm [3.36"])

	ST22	ST33	SA33
A	76.2	95.3	95.3
B min.	87.7	80.0	80.0
B max.	142.7	140.1	140.1

	ST22	ST33	SA33
C1 min.	123.7	158.8	381.6
C2 max.	126.2	161.4	384.1
D	64.0	89.0	89.0
E2 min.	15.9	21.2	21.2
E1 max.	18.4	23.7	23.7
F	25.38	35.00	35.00
G *	2.54	2.54	2.54
H †	73.6	83.8	83.8
J	8.1	8.4	8.4

Dimensions in millimeters

Performance & Mechanical Specs:

		IMA-ST22 (1 STACK, MV21/41)	IMA-ST22 (3 STACK, MV23/43)	IMA-ST33 (1 STACK, MV21/41)	IMA-ST33 (3 STACK, MV23/43)	IMA-SA33 (3 STACK, MV23/43)
CONTINUOUS FORCE	kN	up to 0.45	up to 1.15	up to 1.30	up to 3.77	up to 3.77
	lbf	up to 100	up to 258	up to 292	up to 847	up to 847
PEAK FORCE	kN	up to 1.45	up to 1.45	up to 6.30	up to 11.12	up to 11.12
	lbf	up to 325	up to 325	up to 1417	up to 2500	up to 2500
MAX. VELOCITY	mm/sec	up to 497	up to 497	up to 497	up to 497	up to 497
	in/sec	up to 19.6	up to 19.6	up to 19.6	up to 19.6	up to 19.6
STROKE	mm	76.2 to 304.8	152.4 to 304.8	76.2 to 457.2	152.4 to 457.2	0 to 304.8
	in	3.0 to 12.0	6.0 to 12.0	3.0 to 18.0	6.0 to 18.0	0 to 12.0
TEMP RANGE		-20° to +40° C; -4° to +104° F				
IP RATING		IP69K (Static)				

(Motor/screw selection determines performance. Not all models deliver maximum values listed, i.e.: Maximum thrust may not be available with maximum speed)

ROBOT & DRIVE/CONTROLLER COMPATIBILITY

Compatible feedback, connector(s) and wiring to match the following robot & drive/controller manufacturers:

- Allen Bradley
- Bosch Rexroth
- Kollmorgen
- Siemens
- Beckhoff
- Nidec
- Lenze
- And More



**ACTUATOR
SIZING**

**COMPLETE INFORMATION,
SIZING SOFTWARE AND SOLID
MODELS AVAILABLE AT:**

www.tolomatic.com



**CAD
LIBRARY**

Tolomatic™

EXCELLENCE IN MOTION

COMPANY WITH
QUALITY SYSTEM
CERTIFIED BY DNV GL
= ISO 9001 =
Certified site: Hamel, MN

All brand and product names are trademarks or registered trademarks of their respective owners. Information in this document is believed accurate at time of printing. However, Tolomatic assumes no responsibility for its use or for any errors

that may appear in this document. Tolomatic reserves the right to change the design or operation of the equipment described herein and any associated motion products without notice. Information in this document is subject to change without notice.