

SOLID BEARING RODLESS ELECTRIC ACTUATORS

MXE-S

The MXE-S rodless electric screw-drive actuator is designed for applications requiring moderate load carrying and guidance. The MXE-S actuator utilizes two field replaceable solid bearings that optimize stress distribution for optimal performance.

LIGHTWEIGHT ALUMINUM DESIGN

Clear anodized extrusion design is optimized for rigidity and strength

TRAPEZOIDAL BEARINGS

Field replaceable bearings with trapezoidal design maximizes bearing surface area with less pressure on bearing surfaces for lower wear



YOUR MOTOR HERE

- Wide variety of standard motor mounts machined to your motor of choice. Includes mounting hardware and couplers
- Inline or reverse parallel (foldback) motor mounting options

STAINLESS STEEL DUST BAND

Durable, flexible, fatigue and corrosion resistant stainless steel band is magnetically retained. The dust band keeps contaminants from entering the actuator interior, protecting components for reduced maintenance and increased uptime

NON-BINDING BEARING ARMS

Bearings are tensioned indirectly, providing bind free adjustment

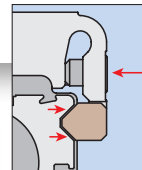

MULTIPLE SCREW TECHNOLOGIES

YOU CAN CHOOSE:

- Solid nuts of bronze or engineered resins offer quiet performance at the lowest cost; anti-backlash available
- Ball screws offer positioning accuracy and repeatability with longer life; low-backlash available



Multi Axis Applications

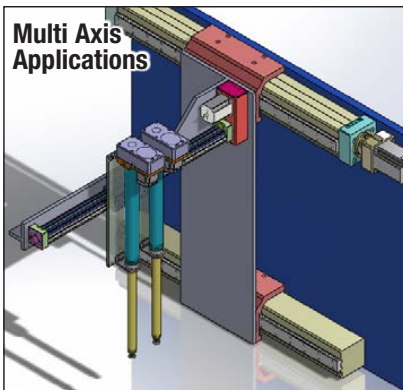

Applications:

- Adhesive Dispensing
- Applying
- Camera Positioning
- Cutting
- High Speed Flying Cut Off
- Inspecting
- Material Cutting
- Parts Transfer
- Pick & Place
- Product Handling
- Slitting
- Spraying
- Stacking
- Storage, Retrieval
- Sorting
- X-Y Gantry, Multi Axis
- Test Functions
- Test Stations
- and many more

Available Options:

Mounting

Mounting Plates; Tube Clamps

Carrier

Auxiliary Carrier, Floating Mount

Sensors

Reed, Solid State PNP or NPN, flush mount, drop in installation

SOLID BEARING RODLESS ELECTRIC ACTUATORS

STANDARD CARRIER

MXE-S

SIZE	MAXIMUM BENDING MOMENTS						MAX. LOAD		MAX. THRUST			
	M _x		M _y		M _z		F _z		Solid Nut		Ball Screw	
	N-m	in-lbs	N-m	in-lbs	N-m	in-lbs	N	lb	N	lbf	N	lbf
16	2.5	22	2.1	19	2.8	25	156	35	200	45	—	—
25	6.8	60	12.4	110	3.8	34	311	70	756	170	578	130
32	11.3	100	39.5	350	15.8	140	667	150	756	170	578	130
40	31.1	275	67.8	600	24.9	220	1,001	225	1,334	300	3,559	800
50	35.6	315	131.0	1,155	38.5	341	1,401	315	1,335	300	12,010	2,700
63	66.1	585	264.0	2,340	58.8	520	2,313	520	1,779	400	19,127	4,300

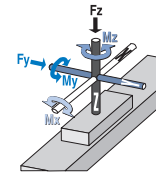

NOTE: Auxiliary Carrier option increases maximum bending moments and load, see [MXE brochure 8300-4000](#) for complete details.

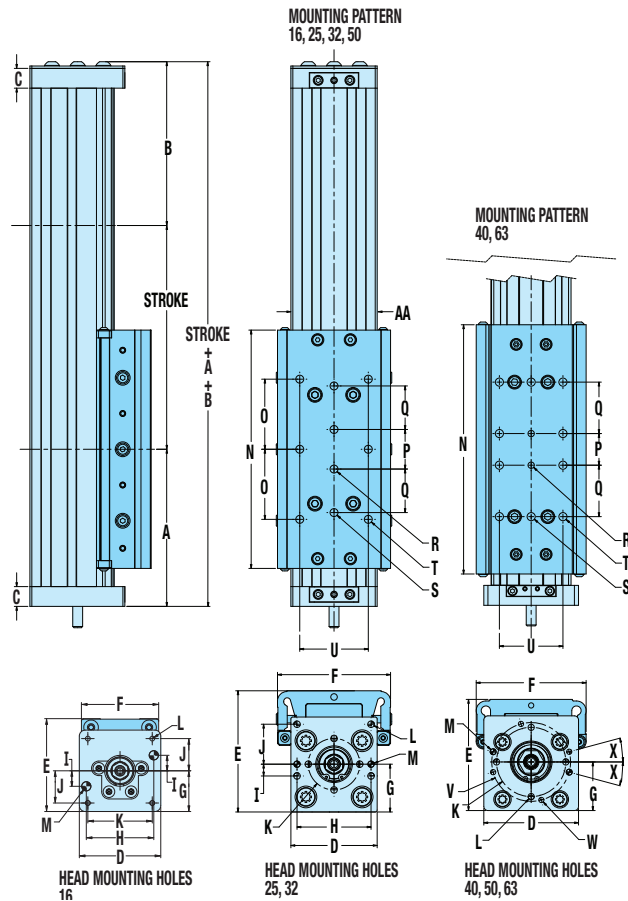

Dimensions

	MXE16	MXE25	MXE32	MXE40	MXE50	MXE63
A	69.1	96.3	100.9	125.2	141.7	211.3
B	72.1	100.6	105.1	130	147.8	216.2
C	12.7	23.4	12.7	16	33.3	47.8
D	42.2	57.2	55.4	75.9	88.1	110.0
E	48.0	58.4	77.8	89.2	112.8	139.7
F	40.1	55.4	72.6	88.2	104.1	142.0
G	21.1	24.1	30.7	39.1	46.2	58.4
H	35.1	47.5	47.5	-	-	-
I	8.1	7.6	7.6	-	-	-
J	16.8	25.7	25.7	-	-	-
K	33.3	Ø33.0	Ø33.0	Ø55.6	Ø68.3	Ø76.5
L	M3x0.5 (4)	M5x0.8 (8)	M5x0.8 (8)	M6x1.0 (4)	M6x1.0 (4)	M6x1.0 (4)
M	Ø4.78 (2)	Ø4.01(2)	Ø4.01 (2)	Ø4.80 (2)	Ø4.78 (2)	Ø4.78 (2)
N	104.6	134.9	153	200	200.9	307.6
O	30.0	39.9	45	-	47.8	-
P	-	25.4	25.4	25.4	63.5	76.2
Q	-	27.2	28	41.3	31.8	38.1
R	-	M6x1.0 (2)	M8x1.25 (2)	M8x1.25 (2)	M10x1.5 (2)	M10x1.5 (2)
S	-	M6x1.0 (2)	M8x1.25 (2)	M8x1.25 (2)	M10x1.5 (2)	M10x1.5 (2)
T	M4x0.7 (6)	M6x1.0 (6)	M8x1.25 (6)	M8x1.25 (8)	M10x1.5 (6)	M10x1.5 (8)
U	30.0	30.0	44.0	51.0	65.8	82.6
V	-	-	-	Ø63.2	Ø76.5	Ø76.5
W	-	-	-	M5x0.8 (4)	M5x0.8 (4)	M5x0.8 (4)
X	-	-	-	15°	15°	15°
AA	30.00	42.00	55.37	64.00	78.74	100.00

Dimensions in millimeters • See [MXE brochure 8300-4000](#) for complete dimension details

TolomaticTM
EXCELLENCE IN MOTION

COMPANY WITH
QUALITY SYSTEM
CERTIFIED BY DNV GL
= ISO 9001 =
Certified site: Hamel, MN

All brand and product names are trademarks or registered trademarks of their respective owners. Information in this document is believed accurate at time of printing. However, Tolomatic assumes no responsibility for its use or for any errors

that may appear in this document. Tolomatic reserves the right to change the design or operation of the equipment described herein and any associated motion products without notice. Information in this document is subject to change without notice.